

## SX-6 Type Industrial Coupling

The SX-6 Type is a standard coupling with two hubs, a spacer, and two disc pack kits. The coupling has two flex planes (one at each disc pack) so it can accommodate parallel misalignment by the angular misalignment in each disc pack. This configuration will also accommodate axial misalignment within the specified limits.

### Features

- Unitized disc pack
- Infinite life when properly sized and aligned
- Accommodates angular, axial, and parallel misalignment
- Torsionally rigid without any back lash
- No need for lubrication or maintenance
- No wearing parts and high resistance to harsh environmental conditions
- Overload Bushings are available, see page D-4

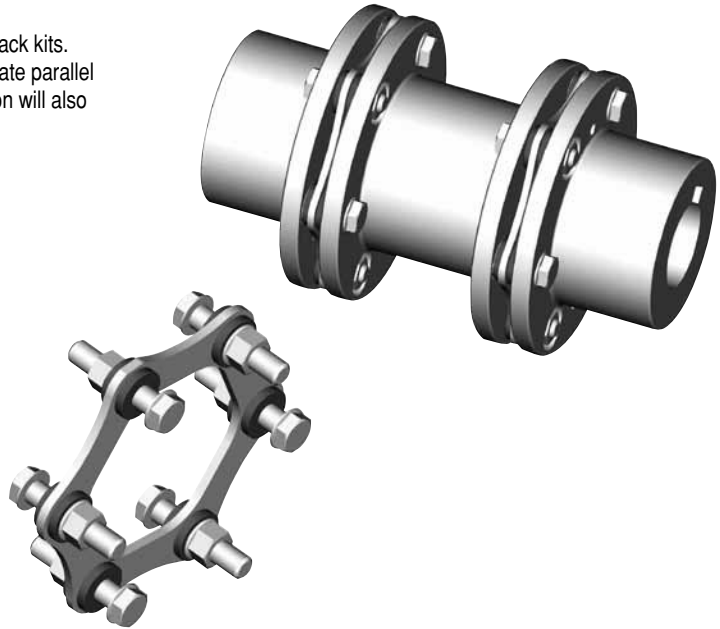

### SX-6 Performance Data

Size	Nominal Torque		Peak Torque		Max Speed		ID1-ID2 Max Bore <sup>3</sup>		Weight <sup>4</sup>		Axial <sup>5</sup> Misalignment ±Δ Ka		Angular <sup>6</sup> Misalignment Max Degrees
	in-lbs	Nm	in-lbs	Nm	RPM	Bal <sup>2</sup> RPM	in	mm	lbs	kg	in	mm	
90-6	2,100	240	4,200	480	9,100	22,700	1.50	38	4.6	2.1	0.059	1.5	1.5°
110-6	5,100	575	10,200	1 150	7,200	18,000	1.81	46	6.4	2.9	0.083	2.1	
132-6	9,700	1 100	19,500	2 200	5,840	14,600	2.38	60	12.1	5.5	0.102	2.6	
158-6	17,700	2 000	35,400	4 000	4,920	12,300	2.76	70	19.0	8.6	0.122	3.1	
185-6	29,200	3 300	58,400	6 600	4,200	10,500	3.13	80	33.1	15.0	0.146	3.7	
202-6	40,700	4 600	81,400	9 200	3,840	9,600	3.50	90	46.3	21.0	0.150	3.8	1°
228-6	62,000	7 000	123,900	14 000	3,400	8,500	3.94	100	66.1	30.0	0.165	4.2	
255-6	90,300	10 200	180,600	20 400	3,080	7,700	4.31	110	88.2	40.0	0.185	4.7	
278-6	125,700	14 200	251,400	28 400	2,800	7,000	4.88	124	125.7	57.0	0.205	5.2	
302-6	177,000	20 000	354,000	40 000	2,560	6,400	5.31	135	163.1	74.0	0.224	5.7	
325-6	221,300	25 000	442,600	50 000	2,400	6,000	5.75	145	196.2	89.0	0.256	6.5	
345-6	274,400	31 000	549,000	62 000	2,200	5,500	6.06	155	240.3	109.0	0.272	6.9	
380-6	374,400	42 300	749,000	84 600	2,040	5,100	6.69	170	321.9	146.0	0.299	7.6	
410-6	505,400	57 100	1,011,000	114 200	1,880	4,700	7.13	180	418.8	190.0	0.323	8.2	
440-6	650,500	73 500	1,301,000	147 000	1,740	4,350	7.69	195	493.8	224.0	0.346	8.8	

- Notes:
- 1 indicates: Operating speed must be equal or less than permissible speed. Permissible speeds could be limited by the weight and the critical speeds of the spacer.
  - 2 indicates: Couplings as manufactured can accommodate maximum speeds as listed. Higher speeds up to the value shown as "Bal" require special balancing.
  - 3 indicates: The maximum bores shown are for cylindrical or taper shafts with keys. For splines and other type bores contact Lovejoy Technical Support.
  - 4 indicates: Weight is given for a complete coupling with minimum BSE and maximum bores.
  - 5 indicates: Axial misalignment is given for two disc packs.
  - 6 indicates: Angular misalignment is given for single disc pack.
  - For higher torque capacities, see SX-8 Type couplings on page D-14 and D-15.

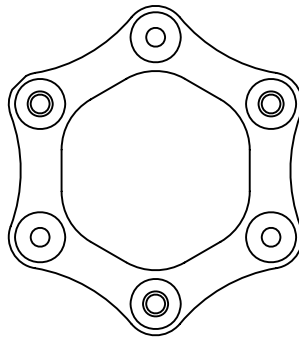
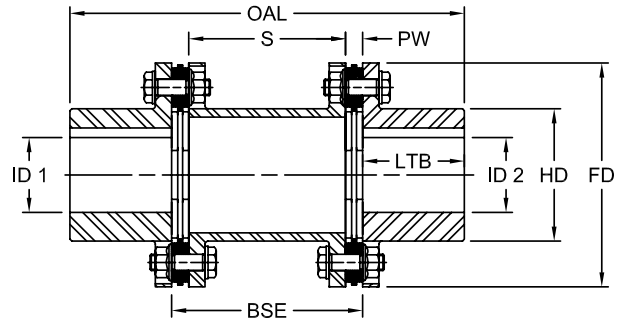
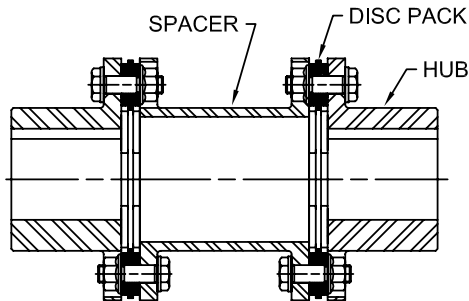

**SX-6 Dimensional Data**

Size	OAL		S		PW		LTB		ID1-ID2 Max Bore <sup>3</sup>		BSE <sup>7</sup> Standard		FD		HD	
	in	mm	in	mm	in	mm	in	mm	in	mm	in	mm	in	mm	in	mm
90-6	5.50	134	1.77	45	0.295	7.5	1.57	40	1.50	38	2.36	60	3.54	90	2.28	58
110-6	7.44	189	2.84	72	0.331	8.4	1.97	50	1.81	46	3.50	89	4.33	110	2.56	65
132-6	8.97	228	3.59	91	0.331	8.4	2.36	60	2.38	60	4.25	108	5.20	132	3.31	84
158-6	10.40	264	4.00	102	0.441	11.2	2.76	70	2.76	70	4.88	124	6.22	158	3.86	98
185-6	11.80	300	4.40	112	0.551	14.0	3.15	80	3.13	80	5.50	140	7.28	185	4.41	112
202-6	13.33	339	5.03	128	0.610	15.5	3.54	90	3.50	90	6.25	159	7.95	202	4.92	125
228-6	14.76	375	5.50	140	0.689	17.5	3.94	100	3.94	100	6.88	175	8.98	228	5.51	140
255-6	16.81	427	6.14	156	0.807	20.5	4.53	115	4.31	110	7.75	197	10.04	255	6.10	155
278-6	18.47	469	6.96	177	0.835	21.2	4.92	125	4.88	124	8.63	219	10.95	278	6.85	174
302-6	19.89	505	7.33	186	0.961	24.4	5.32	135	5.31	135	9.25	235	11.89	302	7.48	190
325-6	21.42	544	7.95	202	1.024	26.0	5.71	145	5.75	145	10.00	254	12.80	325	8.07	205
345-6	22.83	580	8.41	214	1.110	28.2	6.10	155	6.06	155	10.63	270	13.58	345	8.55	217
380-6	25.08	637	9.16	233	1.260	32.0	6.70	170	6.69	170	11.68	297	14.96	380	9.37	238
410-6	27.18	690	10.01	254	1.307	33.2	7.28	185	7.13	180	12.62	321	16.14	410	10.04	255
440-6	28.55	725	10.32	262	1.433	36.4	7.68	195	7.69	195	13.19	335	17.32	440	10.75	273

Notes: ■ 7 indicates: BSE is the distance between shaft ends and is a variable parameter.  
 ■ Metric dimensions are rounded to the nearest 'mm' except where otherwise shown.