

Roquet

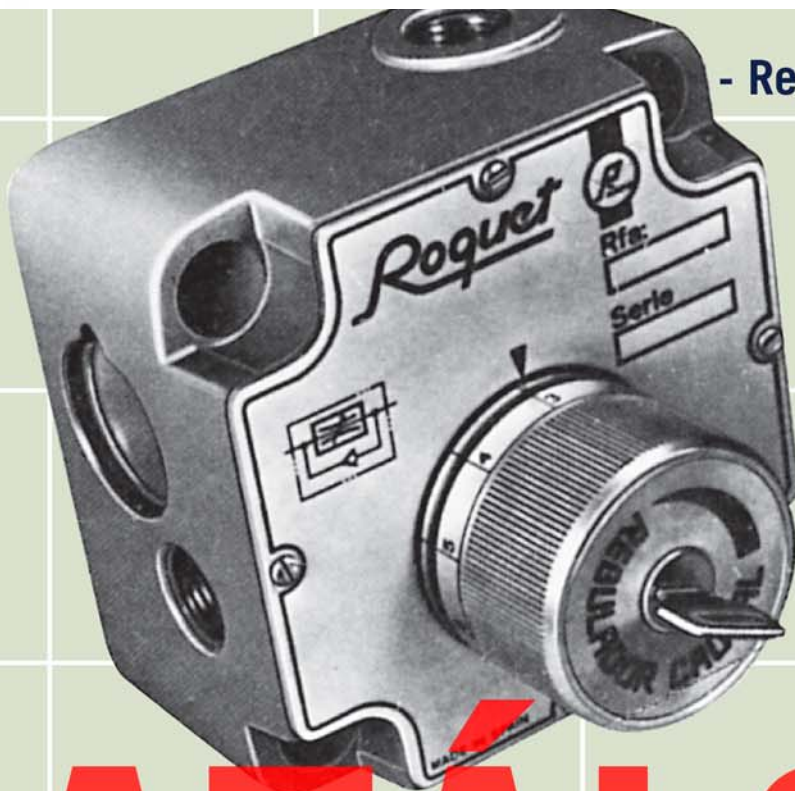

LEHENGOA, S.A.

- Reguladores de caudal



CATÁLOGO

Reguladores de caudal Flow control valves



Este tipo de válvulas permiten una regulación rápida y exacta del flujo en un sentido, prácticamente insensible a las variaciones de presión y temperatura.

En este catálogo podrán encontrar reguladores de dos o tres vías, conexión por racores o por placa base según normas CETOP y para caudales distintos según se indica a la nomenclatura de referencias.

Cuando se emplean modelos de tres vías se tiene la oportunidad de mandarles a distancias mediante pilotaje o incorporarles una válvula limitadora de presión para preservar el circuito.

En todos los modelos según CETOP se puede incorporar un limitador de carrera regulable para cuando se actúe con caudal pequeño, tal como se indica en las hojas técnicas.

This type of valves allows a fast and accurate adjustment in a flow direction, and it is practically unaffected by pressure and temperature variations.

In this catalogue you will find two and three way flow control valves with threaded or CETOP sub-plate mounting and for different flow rates, as indicated in the references guide.

Three way flow control valves can be remote controlled and a relief valve can be in-built to protect the circuit.

When small flow rates are controlled an adjustable stroke limit can be in-built in all CETOP types, as indicated in the technical pages.

Indice

Características generales	2
Nomenclatura de referencia	3
Diagramas	4
Regulador de caudal 2 vías 1/2"	5
Regulador de caudal 3 vías 1/2"	7
Regulador de caudal 2 vías 3/4"	9
Regulador de caudal 3 vías 3/4"	11
Regulador de caudal 2 vías	15
Regulador de caudal 3 vías	18
Repartidor de caudal	22
Válvula de frenado	26
Estrangulador cierre total	27

Index

General data	2
Coding system	3
Diagrams	4
Flow control valve 2 ways 1/2"	5
Flow control valve 3 ways 1/2"	7
Flow control valve 2 ways 3/4"	9
Flow control valve 3 ways 3/4"	11
Flow control valve 2 ways	15
Flow control valve 3 ways	18
Flow divider	22
Braking valve	26
Restrictor full closing	27

NOMENCLATURA DE REFERENCIAS				3VCR	B	L	06	P	160	F	CODING SYSTEM	
------------------------------------	--	--	--	-------------	----------	----------	-----------	----------	------------	----------	----------------------	--

Funciones <i>Function</i>	
2VCR	2 vías fijación según CETOP <i>2 ways with CETOP fixing holes</i>
3VCR	3 vías fijación según CETOP <i>3 ways with CETOP fixing holes</i>

Tipo volante <i>Knob Type</i>	
B	Volante con llave <i>Knob with key</i>
S	Volante sin llave <i>Knob without key</i>

Función <i>Function</i>	
L	Válvula limitadora (sólo para el 3 vías) <i>Pressure relief valve (only in 3 ways valve)</i>

Presión de taraje <i>Setting pressure</i>		bar
B	5-80	
D	80-175	
F	175-250	
Sólo para función L <i>Only for function L</i>		

Caudal nominal en l/min. <i>Nominal flow rate l/min.</i>	
65	1/2" BSP
165	3/4" BSP

Forma de conexión <i>Mounting form</i>	
R	Racores <i>Screw</i>
P	Placa <i>Sub-plate</i>

Tamaño <i>Size</i>	
04	1/2" BSP
06	3/4" BSP

Nota: Cuando se desee un regulador con limitador de carrera se añadirá detrás la referencia "LC".

Note: When a flow control valve with stroke limit is required "LC" will be added at the reference end.



LEHENGOTAK, S.A.

$\Delta p \rightarrow Q$ a 23 cSt

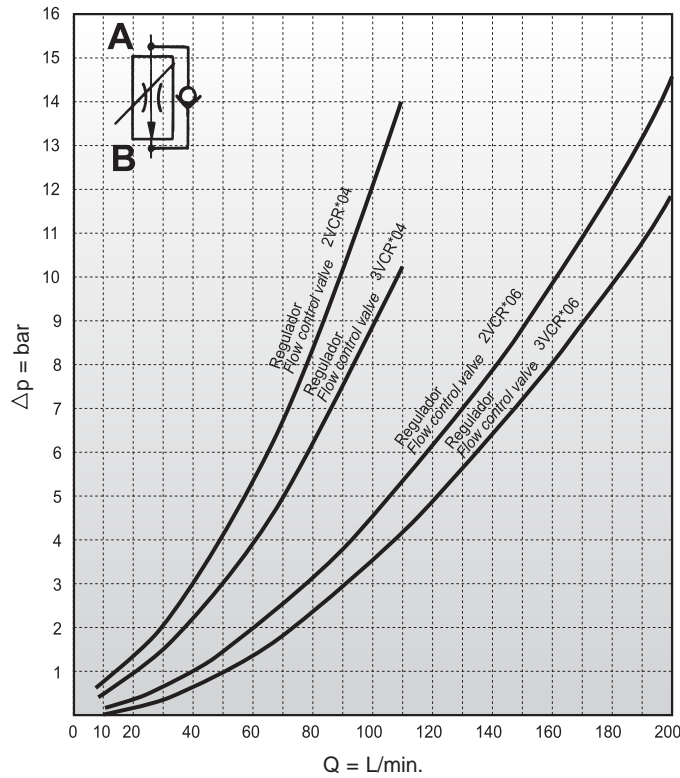

PRESION - CAUDAL
PRESSURE - FLOW RATE

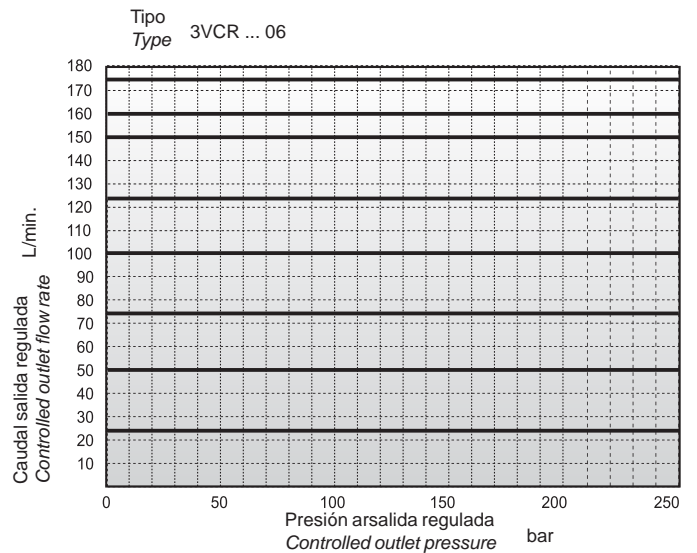
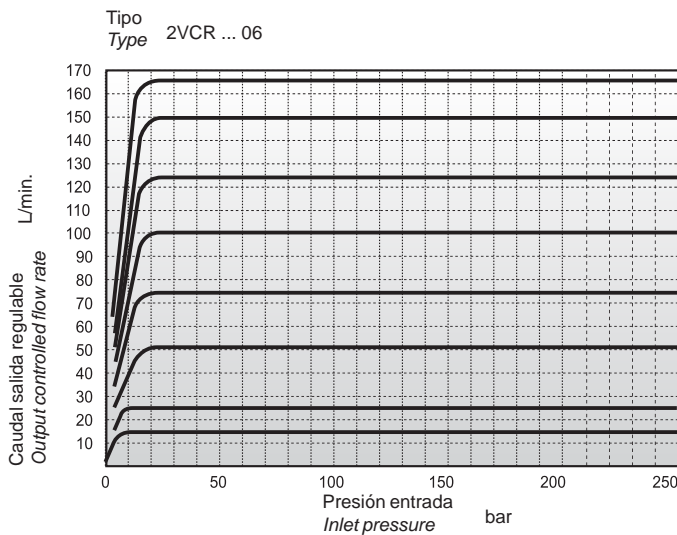
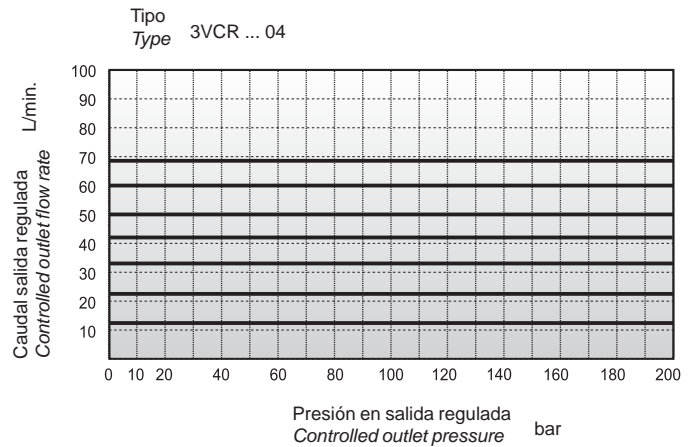
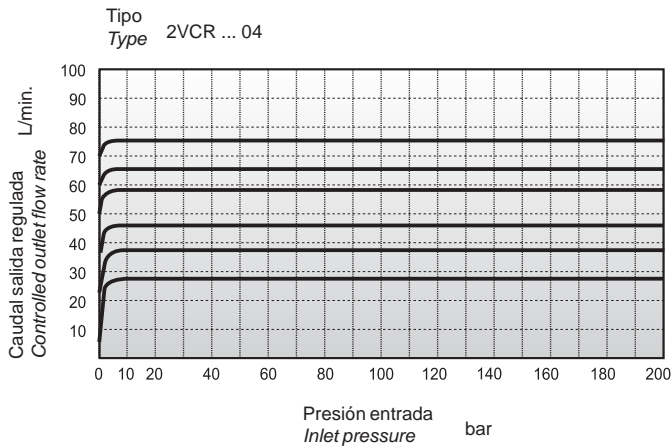

REGULADOR DE CAUDAL 2 vías 1/2" - FLOW CONTROL VALVE 2 ways 1/2"

Datos técnicos hidráulicos Hydraulic technical data

Presión máxima de trabajo Max. working pressure	250 bar
Caudal nominal Nominal flow rate	65 L/min.
Caudal mínimo Minimum flow rate	1 L/min.
Presión mín. de regulación Min. adjusting pressure	5-7 bar
Fluido recomendado Fluid to be used	ISO 6743 Tipo HM, HV ó HG ISO 3448 Cat. VG32, VG46
Gama de temperaturas del fluido Fluid temperature range	-20°C... +80°C
Gama de viscosidades Manual viscosity range	4—500 cSt.
Grado de limpieza del aceite Recommended fluid cleanliness	16/13 s/. ISO 4406 - RP70H
Peso aproximado Aprox. weight	4,3 Kg.



Serie
Type 2VCR

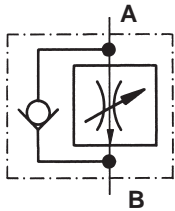

- A Entrada del aceite
Oil inlet
- B Salida regulada del aceite
Controlled oil outlet

Montaje por racores Screwed mounting

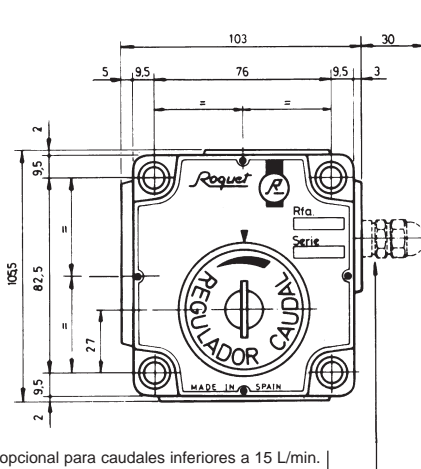

Tope opcional para caudales inferiores a 15 L/min.
Optional for flow rates smaller than 15 L/min.

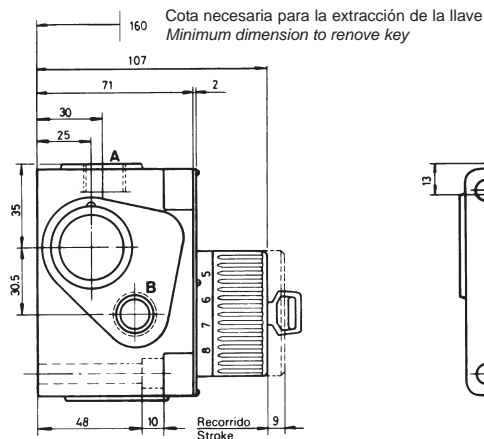

Montaje por placa Sub-plate mounting

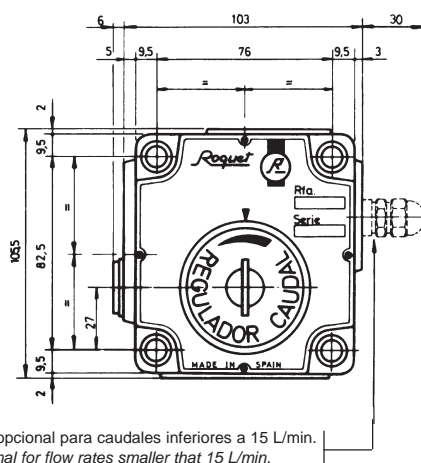

Tope opcional para caudales inferiores a 15 L/min.
Optional for flow rates smaller than 15 L/min.

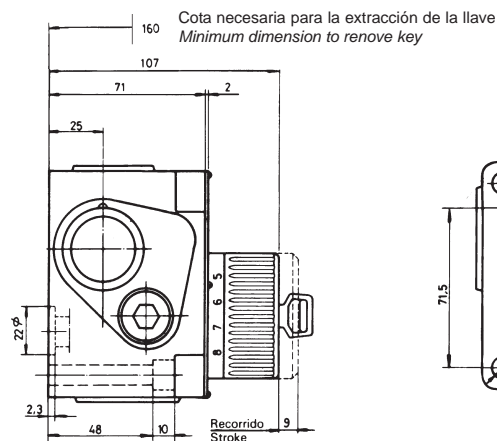

Ejemplo para pedido de recambios
Example to order spare parts

Cantidad Quantity	Denominación Description	Nº de la pieza Part number	Referencia según la placa Rfa. according serial number plate
1	Tapón tope corredera Plug	5	Para regulador For flow control valve 2VCRB04P65D

Montaje por racores
Screwed mounting

Montaje por placa
Sub-plate mounting

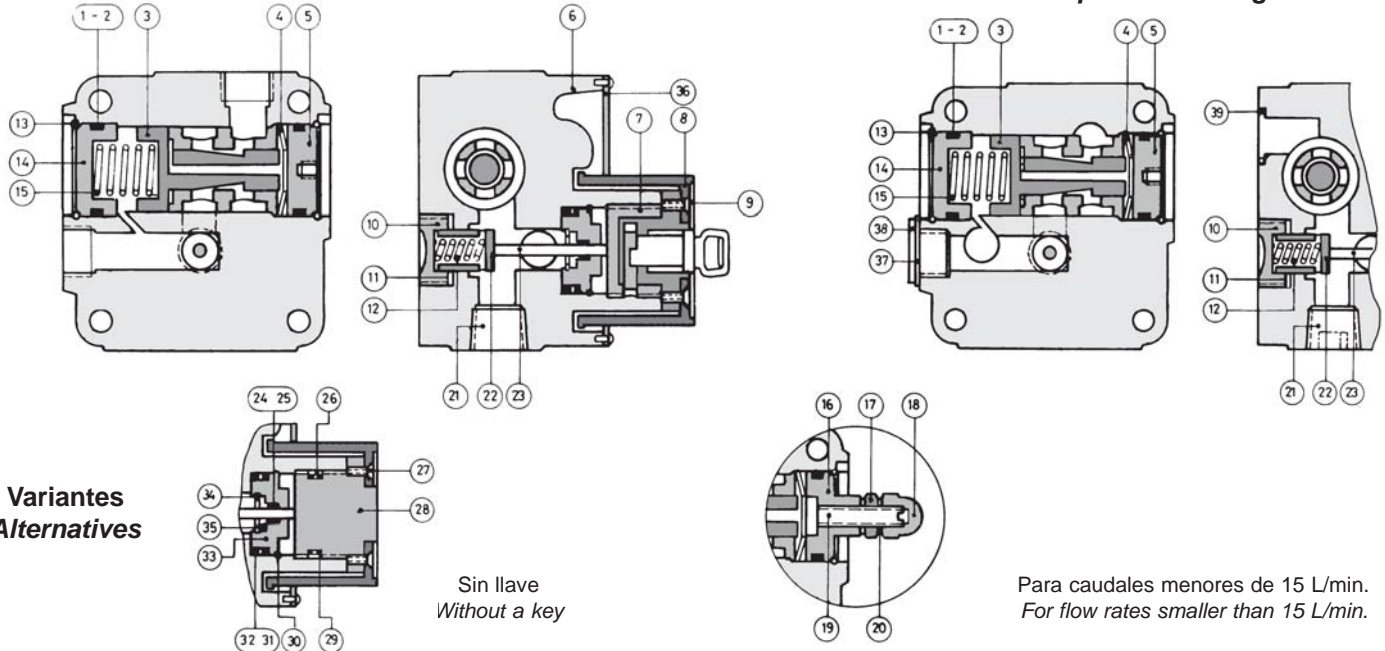

Núm.	Denominación Description	Cant. Quant.	Núm.	Denominación Description	Cant. Quant.	Núm.	Denominación Description	Cant. Quant.
1	Junta tórica O ring	2	15	Muelle Spring	1	29	Junta tórica O ring	2
2	Junta antiextrusión Anti-extrusion ring	2	16	Tapón tope corredera Plug	1	30	Anillo elástico Elastic ring	1
3	Conj. guía y corredera Spool and guide set	1	17	Contratuercas Locknut	1	31	Junta tórica O Ring	1
4	Muelle de platillo Disc spring	1	18	Tuerca sombrerete Blin nut	1	32	Junta antiextrusión Anti-extrusion ring	1
5	Tapón tope corredera Plug	1	19	Tornillo regulación Adjusting screw	1	33	Guía varilla empuje Pushing pin guide	1
6	Cuerpo regulador Valve housing	1	20	Junta cobre Copper gasket	1	34	Anillo elástico Elastic ring	1
7	Conj. guía y volante Knob guide	1	21	Tapón cónico Taper screw	1	35	Tope junta tórica O ring fixing part	1
8	Conjunto volante Knob set	1	22	Embolo estrangulador Spool	1	36	Placa de referencias Serial number plate	1
9	Placa distintivo Description plate	1	23	Varilla empuje Pushing pin	1	37	Junta metal-buna Metal bonded gasket	1
10	Tapón posterior Plug	1	24	Junta antiextrusión Anti-extrusion ring	1	38	Tapón Plug	1
11	Junta Gasket	1	25	Junta tórica O ring	1	39	Junta tórica O ring	2
12	Muelle Spring	1	26	Tope freno volante Knob brake	2			
13	Anillo elástico Elastic ring	2	27	Tornillo fijación volante Screw	2			
14	Tapón guía muelle Plug	1	28	Soporte volante Knob				

ACCESORIOS. Requieren pedido por separado
ACCESSORIES. That need separate order

Placa base Sub-plates	Rfa. 273001-273002	Según necesidades According requirements
Tornillos sujeción Fixing screws	4 Tornillos Screws	DIN-912 M8x65 Par de apriete Fit torque 30-35 Nm.
Arandelas de seguridad Safety Washers	4 Arandelas Washers	DIN-7980 Ø 8

REGULADOR DE CAUDAL 3 vías 1/2" - FLOW CONTROL VALVE 3 ways 1/2"

Datos técnicos hidráulicos Hydraulic technical data	
Presión máxima de trabajo <i>Max working pressure</i>	250 bar
Caudal nominal <i>Nominal flow rate</i>	65 L/min.
Caudal mínimo <i>Minimum flow rate</i>	1 L/min.
Presión min. de regulación <i>Min. adjusting pressure</i>	5-7 bar
Fluido recomendado <i>Fluid to be used</i>	ISO 6743 Tipo HM, HV ó HG ISO 3448 Cat. VG32, VG46
Gama de temperaturas del fluido <i>Fluid temperature range</i>	-20°C... +80°C
Gama de viscosidades <i>Manual viscosity range</i>	4—500 cSt.
Grado de limpieza del aceite <i>Recommended fluid cleanliness</i>	16/13 s/. ISO 4406 - RP70H
Peso aproximado <i>Aprox. weight</i>	4,3 Kg.



Serie
Type 3VCR

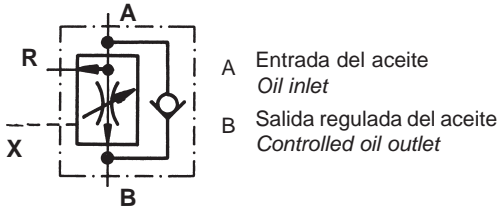

- R Aceite sobrante
Exceeding flow rate
- X Toma opcional puesta en vacío
Optional inlet to unload valve

Montaje por racores
Screwed mounting

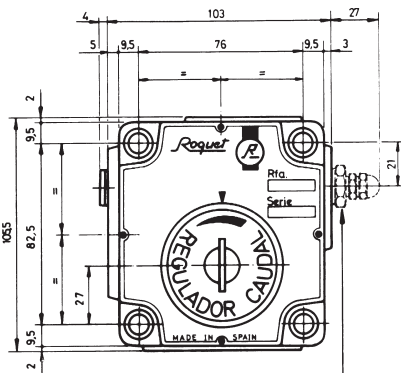

Situación válvula limitadora (opcional)
Optional relief valve position

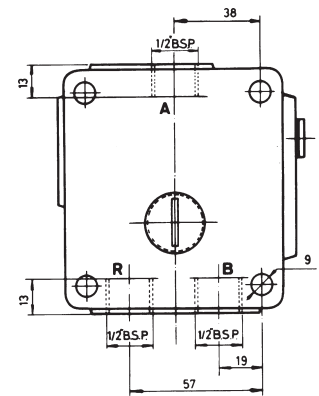
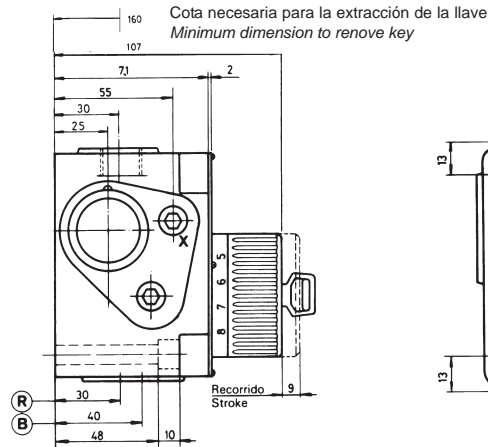

Montaje por placa
Sub-plate mounting

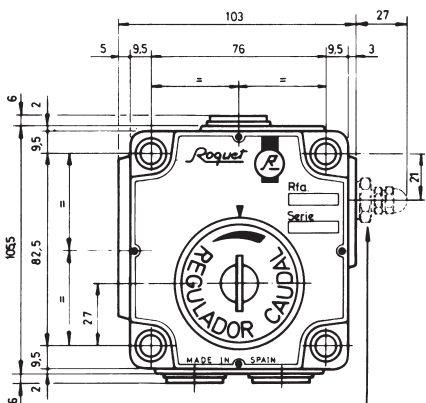

Situación válvula limitadora (opcional)
Optional relief valve position

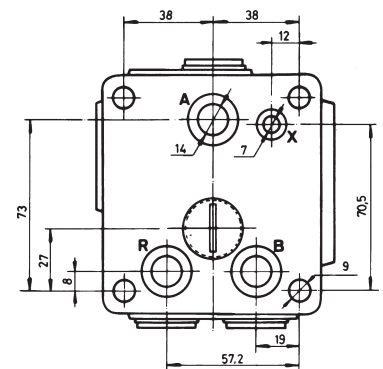
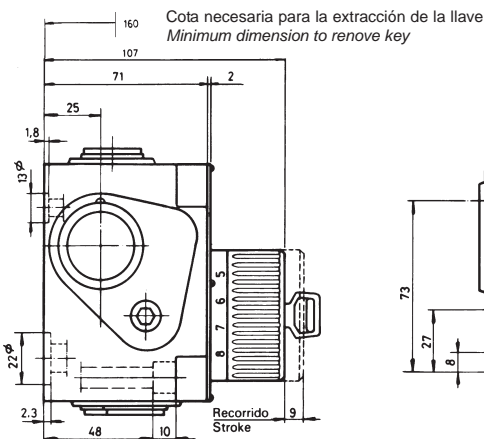

Ejemplo para pedido de recambios
Example to order spare parts

Cantidad Quantity	Denominación Description	Nº de la pieza Part number	Referencia según la placa Rfa. according serial number plate
1	Conjunto guía y corredera Spool and guide set	3	Para regulador For flow control valve 3VCRBL04P650

Montaje por racores
Screwed mounting

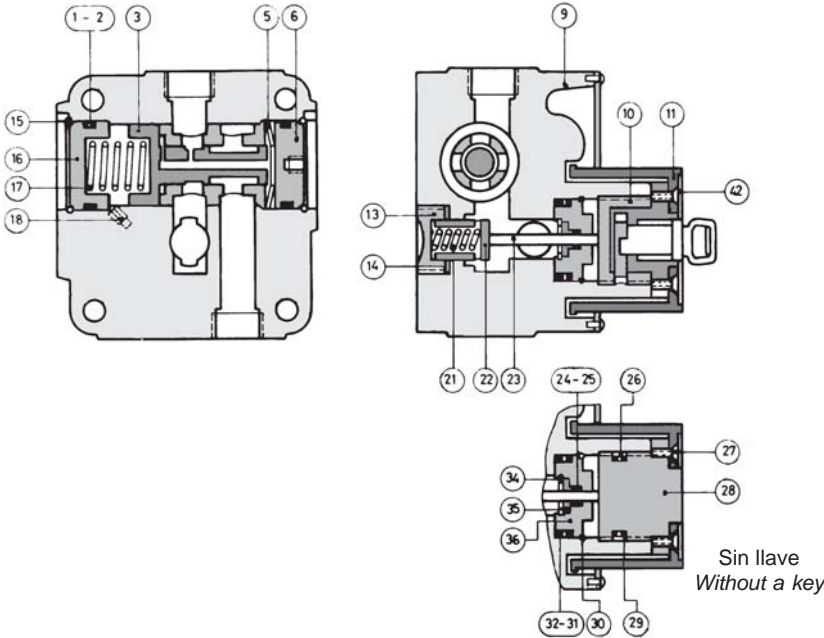

Montaje por placa
Sub-plate mounting

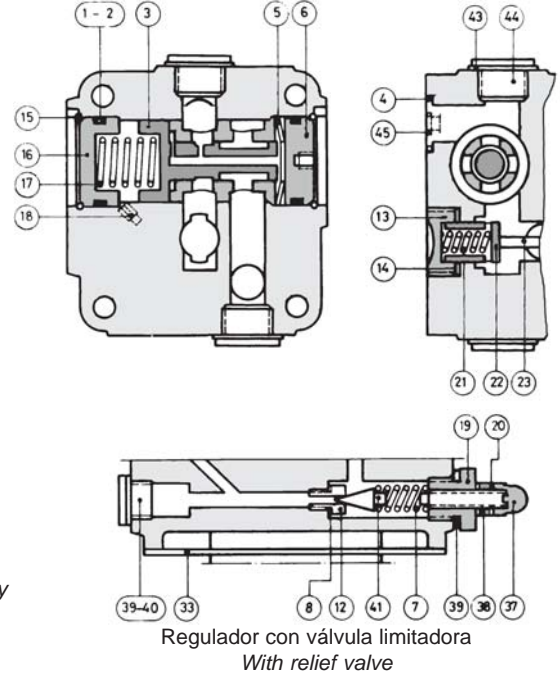

NUM.	Denominación Description	Cant. Quant.	NUM.	Denominación Description	Cant. Quant.	NUM.	Denominación Description	Cant. Quant.
1	Junta tórica O Ring	2	16	Tapón guía muelle Plug	1	31	Junta tórica O Ring	1
2	Junta anti-extrusión Anti-extrusion ring	2	17	Muelle recuperación Spring	1	32	Junta anti-extrusión Anti-extrusion ring	1
3	Conj. guía y corredera Spool and guide set	1	18	Chiclé Throttle	1	33	Placa de referencias Serial number plate	1
4	Junta tórica O Ring	3	19	Tornillo adaptador Adaptor screw	1	34	Anillo elástico Elastic ring	1
5	Muelle de platillo Disc spring	1	20	Junta cobre Cooper gasket	2	35	Tope junta tórica O Ring fixing part	1
6	Tapón tope corredera Plug	1	21	Muelle Spring	1	36	Guía varilla empuje Pushing pin guide	1
7	Muelle válvula reguladora Spring	1	22	Embolo extrangulador Throttle spool	1	37	Tuerca sombrerete Blind nut	1
8	Junta cobre Cooper gasket	1	23	Varilla empuje Pushing pin	1	38	Contratuercas Locknut	1
9	Cuerpo regulador Valve housing	1	24	Junta anti-extrusión Anti-extrusion ring	1	39	Junta metal-buna Metal bonded-gasket	2
10	Conj. guía y volante Knob guide	1	25	Junta tórica O Ring	1	40	Tapón Plug	1
11	Conjunto volante Knob set	1	26	Tope freno volante Knob brake	2	41	Válvula Valve	1
12	Asiento válvula limitadora Relief valve seat	1	27	Tornillo fijación volante Screw	2	42	Placa Description plate	1
13	Tapón posterior Plug	1	28	Soporte volante Knob	1	43	Junta metal-buna Metal bonded-gasket	3
14	Junta metal-buna Metal bonded-gasket	1	29	Junta tórica O Ring	2	44	Tapón Plug	3
15	Anillo elástico Elastic ring	1	30	Anillo elástico Elastic ring	1	45	Junta tórica O Ring	1

ACCESORIOS. Requieren pedido por separado
ACCESSORIES. That need separate order

Placa base Sub-plates	Rfa. 272001-272002	Según necesidades According requirements
Tornillos sujeción Fixing screws	4 Tornillos Screws	DIN-912 M8x65 Par de apriete Fit torque 30-35 mm.
Arandelas de seguridad Safety Washers	4 Arandelas Washers	DIN-7980 Ø 8

REGULADOR DE CAUDAL 2 vías 3/4" - FLOW CONTROL VALVE 2 ways 3/4"

Datos técnicos hidráulicos <i>Hydraulic technical data</i>	
Presión máxima de trabajo <i>Max working pressure</i>	250 bar
Caudal nominal <i>Nominal flow rate</i>	160 L/min.
Caudal mínimo <i>Minimum flow rate</i>	10 L/min.
Presión min. de regulación <i>Min. adjusting pressure</i>	7 bar
Fluido recomendado <i>Fluid to be used</i>	ISO 6743 Tipo HM, HV ó HG ISO 3448 Cat. VG32, VG46
Gama de temperaturas del fluido <i>Fluid temperature range</i>	-20°C... +80°C
Gama de viscosidades <i>Manual viscosity range</i>	4—500 cSt.
Grado de limpieza del aceite <i>Recommended fluid cleanliness</i>	16/13 s/. ISO 4406 - RP70H
Peso aproximado <i>Aprox. weight</i>	6,7 Kg.



Serie
Type 2VCR

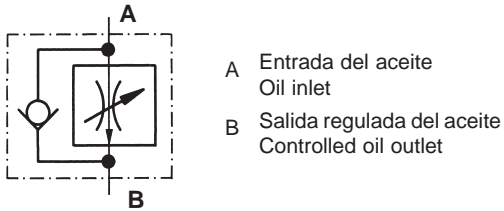

Montaje por racores
Screwed mounting

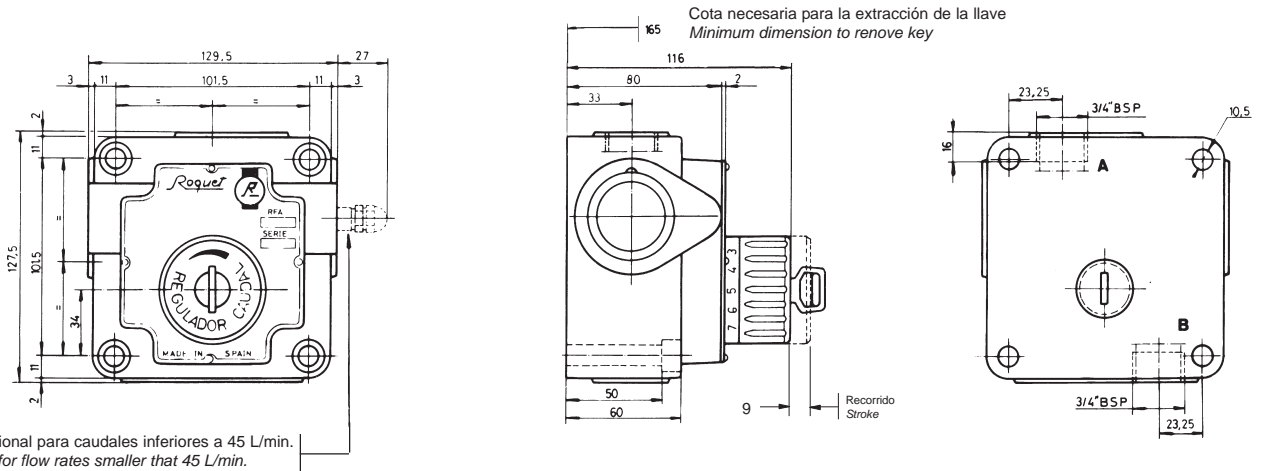

Montaje por placa
Sub-plate mounting

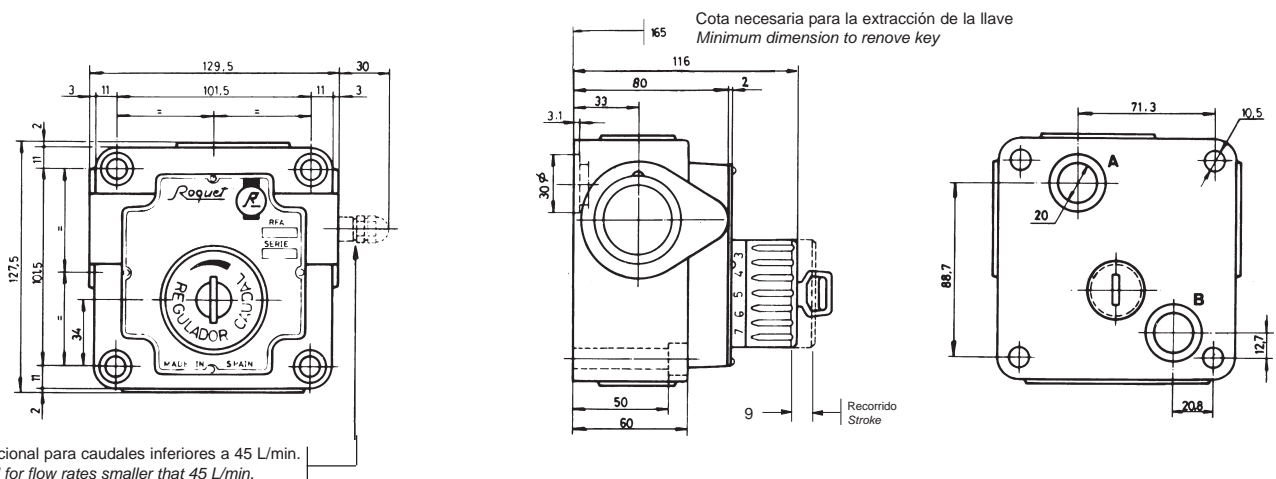

Ejemplo para pedido de recambios
Example to order spare parts

Cantidad Quantity	Denominación Description	Nº de la pieza Part number	Referencia según la placa Rfa. according serial number plate
1	Conjunto guía y corredera Spool and guide set	3	Para regulador For flow control valve 2VCR806P160F

Montaje por racores
Screwed mounting

Montaje por placa
Sub-plate mounting

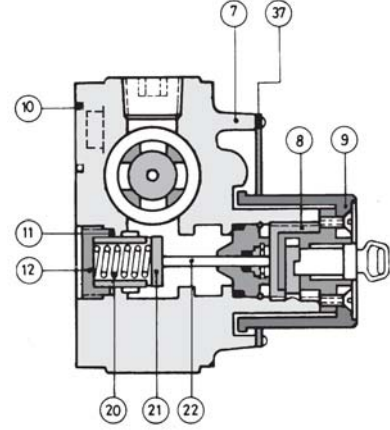
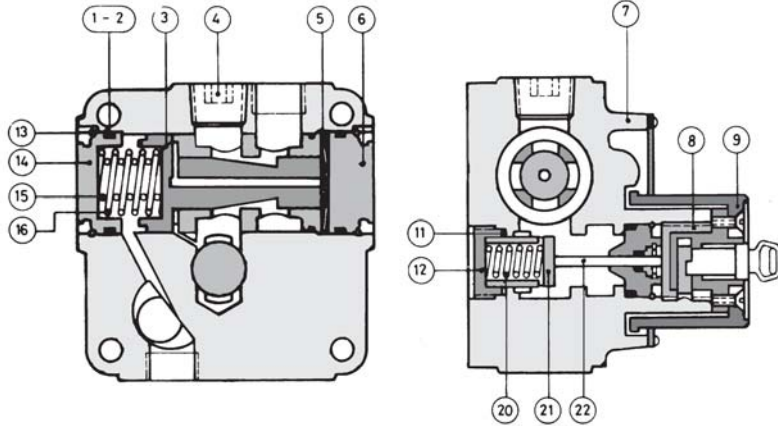

Variantes
Alternatives

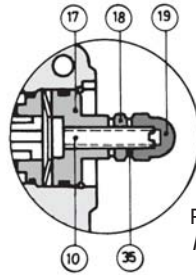

Para caudales menores de 15 L/min.
 For flow rates smaller than 15 L/min.

Sin llave
 Without a key

NUM.	Denominación Description	Cant. Quant.	NUM.	Denominación Description	Cant. Quant.	NUM.	Denominación Description	Cant. Quant.
1	Junta tórica O Ring	2	14	Tapón guía muelle Plug	1	27	Soporte volante Knob	1
2	Junta anti-extrusión Anti-extrusion ring	2	15	Muelle Spring	1	28	Junta tórica O Ring	2
3	Conj. guía y corredera Spool and guide set	1	16	Muelle Spring	1	29	Anillo elástico Elastic ring	1
4	Tapón Plug	1	17	Tapón tope corredera Plug	1	30	Junta tórica O Ring	1
5	Muelle de platillo Disc spring	1	18	Contratuercas Lock nut	1	31	Junta anti-extrusión Anti-extrusion ring	1
6	Tapón tope corredera Plug	1	19	Tuerca sombrerete Blin nut	1	32	Guía varilla empuje Pushing pin guide	1
7	Cuerpo regulador Valve housing	1	20	Muelle Spring	1	33	Tope junta tórica O Ring fixing part	1
8	Conj. guía y volante Knob guide	1	21	Embolo estrangulador Spool	1	34	Anillo elástico Elastic ring	1
9	Conjunto volante Knob set	1	22	Varilla empuje Pushing pin	1	35	Junta cobre Cooper gasket	2
10	Juntas tóricas O Ring	2	23	Junta anti-extrusión Anti-extrusion ring	1	36	Tornillo regulación Adjusting screw	1
11	Junta Gasket	1	24	Junta tórica O Ring	1	37	Placa de referencias Serial number plate	1
12	Tapón posterior Plug	1	25	Tope freno volante Knob brake	2	38	Placa distintivo Description plate	1
13	Anillo elástico Plug	2	26	Tornillo fijación volante Screw	2			

ACCESORIOS. Requieren pedido por separado
ACCESSORIES. That need separate order

Placa base Sub-plates	Rfa. 275001-275002	Según necesidades According requirements
Tornillos sujeción Fixing screws	4 Tornillos Screws	DIN-912 M10x65 Par de apriete Fit torque 72-47 mm.
Arandelas de seguridad Safety Washers	4 Arandelas Washers	DIN-7980 Ø 10

REGULADOR DE CAUDAL 3 vías 3/4" - FLOW CONTROL VALVE 3 ways 3/4"

Datos técnicos hidráulicos <i>Hydraulic technical data</i>	
Presión máxima de trabajo <i>Max working pressure</i>	250 bar
Caudal nominal <i>Nominal flow rate</i>	160 L/min.
Caudal mínimo <i>Minimum flow rate</i>	10 L/min.
Presión min. de regulación <i>Min. adjusting pressure</i>	7 bar
Fluido recomendado <i>Fluid to be used</i>	ISO 6743 Tipo HM, HV ó HG ISO 3448 Cat. VG32, VG46
Gama de temperaturas del fluido <i>Fluid temperature range</i>	-20°C... +80°C
Gama de viscosidades <i>Manual viscosity range</i>	4—500 cSt.
Grado de limpieza del aceite <i>Recommended fluid cleanliness</i>	16/13 s/. ISO 4406 - RP70H
Peso aproximado <i>Aprox. weight</i>	6,7 Kg.



Serie
Type 3VCR

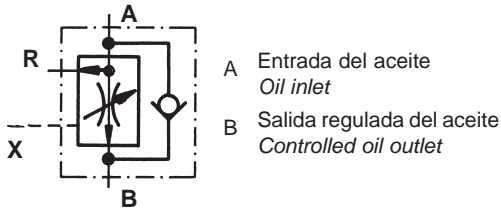

Montaje por racores
Screwed mounting

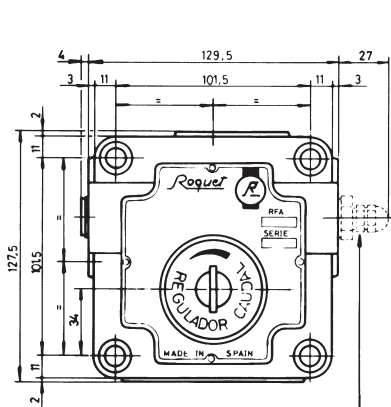

Situación válvula limitadora (opcional)
Optional relief valve position

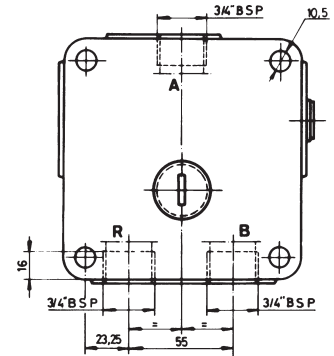
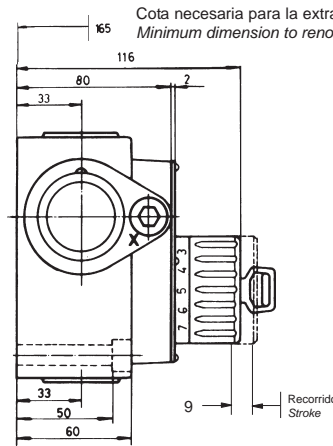

Montaje por placa
Sub-plate mounting

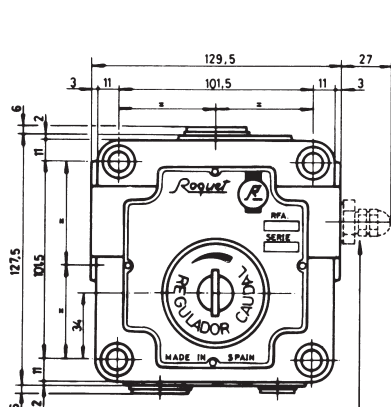

Situación válvula limitadora (opcional)
Optional relief valve position

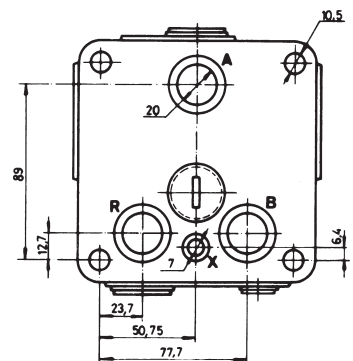
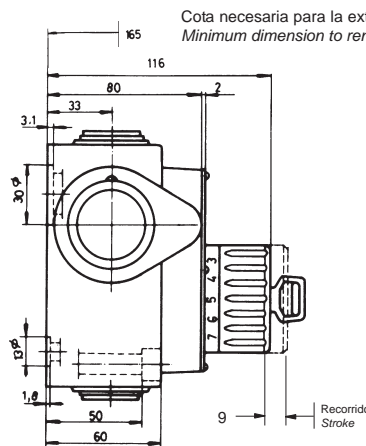

Ejemplo para pedido de recambios
Example to order spare parts

Cantidad Quantity	Denominación Description	Nº de la pieza Part number	Referencia según la placa Rfa. according serial number plate
1	Conjunto volante Knob set	8	Para regulador For flow control valve 3VCRBL06P160F

Montaje por racores
Screwed mounting

Montaje por placa
Sub-plate mounting

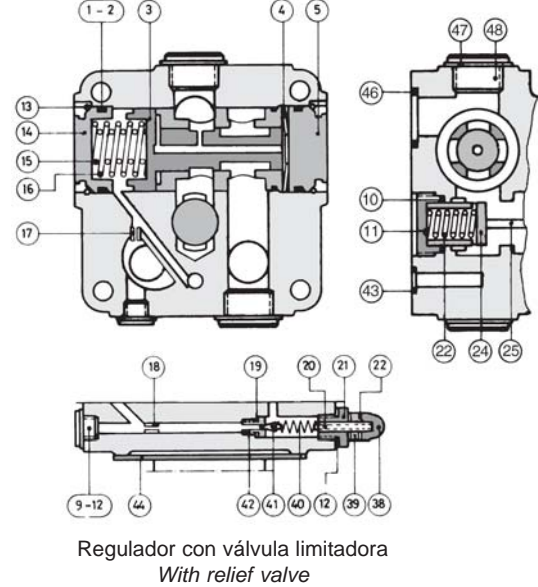
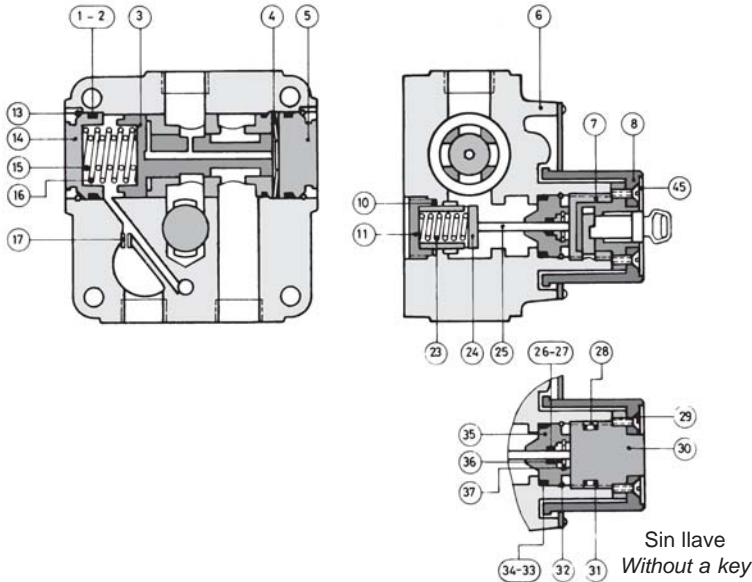

NUM.	Denominación Description	Cant. Quant.	NUM.	Denominación Description	Cant. Quant.	NUM.	Denominación Description	Cant. Quant.
1	Junta tórica O Ring	2	17	Muelle recuperación corredera Spring	1	33	Junta tórica O Ring	1
2	Junta anti-extrusión Anti-extrusion ring	2	18	Tornillo con taladro calibrado Drilled screw	1	34	Junta anti-extrusión Anti-extrusion ring	1
3	Conj. guía y corredera Spool and guide set	1	19	Junta cobre Cooper gasket	1	35	Guía varilla empuje Pushing pin guide	1
4	Muelle de platillo Disc spring	1	20	Tornillo regulación Adjusting screw	1	36	Pieza fijación junta tórica O Ring pin guide	1
5	Tapón tope corredera Plug	1	21	Tornillo adaptador Adaptor screw	1	37	Anillo elástico Elastic ring	1
6	Cuerpo regulador Valve housing	1	22	Juntas cobre Cooper gasket	2	38	Tuerca sombrerete Blind nut	1
7	Conj. guía volante y cerradura Knob guide and lock set	1	23	Muelle recuperador émbolo Spring	1	39	Contratuercas Locknut	1
8	Conjunto volante Knob set	1	24	Émbolo estrangulador Throttle spool	1	40	Muelle válvula limitadora Spring	1
9	Tapón Plug	1	25	Varilla empuje Pushing pin	1	41	Válvula limitadora Spring	1
10	Junta de teflón Ptfе ring	1	26	Junta tórica O Ring	1	42	Asiento válvula Relief valve	1
11	Tapón posterior Plug	1	27	Junta anti-extrusión Anti-extrusion ring	1	43	Junta tórica O Ring	1
12	Juntas metal-buna Metal bonded-gasket	2	28	Tope freno volante Knob brake	2	44	Placa referencias Serial number plate	1
13	Anillo elástico Elastic ring	2	29	Tornillos fijación volante Screw	2	45	Placa distintivo Description plate	1
14	Tapón guía muelle Plug	1	30	Pieza fijación volante sin llave Part for knob without key	1	46	Junta tórica O Ring	3
15	Muelle recuperación corredera Spring	1	31	Junta tórica O Ring	2	47	Junta metal-buna Metal bonded gasket	3
16	Tapón Plug	1	32	Anillo elástico Elastic ring	1	48	Tapón Plug	3

ACCESORIOS. Requieren pedido por separado
ACCESSORIES. That need separate order

Placa base Sub-plates	Rfa. 274001-274002	Según necesidades According requirements
Tornillos sujeción Fixing screws	4 Tornillos Screws	DIN-912 M10x65 Par de apriete Fit torque 42-47 mm.
Arandelas de seguridad Safety Washers	4 Arandelas Washers	DIN-7980 Ø 10

Placas base regulador caudal 2 vías
Sub-plates

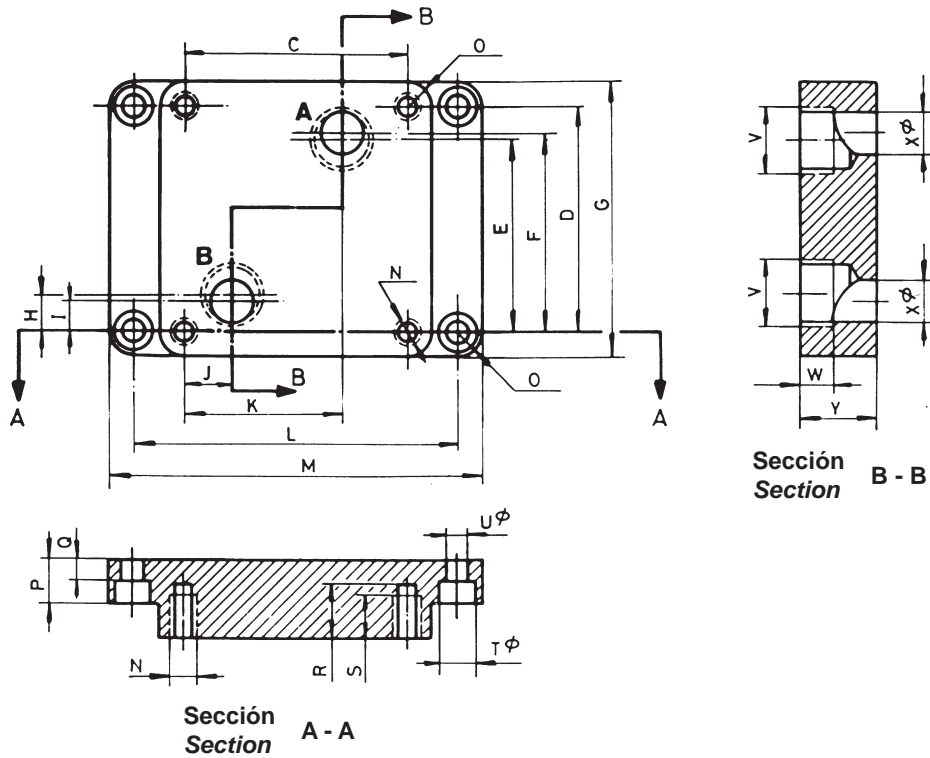

Referencia	C	D	E	F	G	H	I	J	K	L	M	N	O	P	Q	R	S	T	U	V	W	X	Y	Peso kg. Weight kg.
273001	76	82,5	-	71,5	102,5	-	30	9,5	55	114,5	134,5	M.8	R.10	20	11	20	15	14,5	9,5	3/8" B.S.P.	13	14	25	2,100
273002																				1/2" B.S.P.	15			
275001	101,5	101,5	85	89	123,5	17	12,7	20,8	71,3	146	168	M.10	R.11	20	10	25	20	17,5	11	3/4" B.S.P.	15,5	20	35	4,500
275002																				1" B.S.P.	16,5			

Placas base regulador caudal 3 vías
Sub-plates

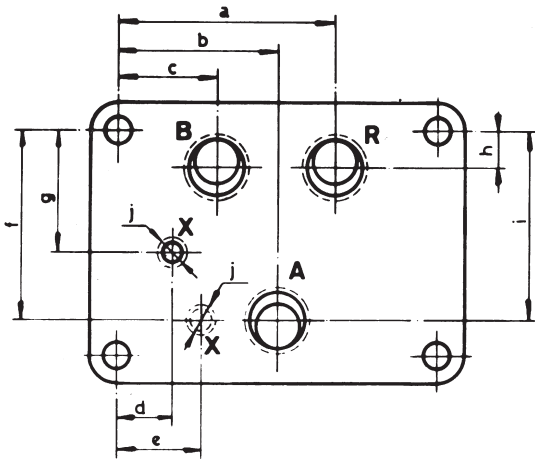
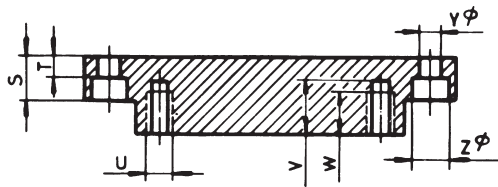
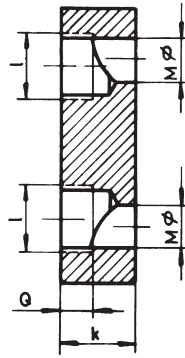
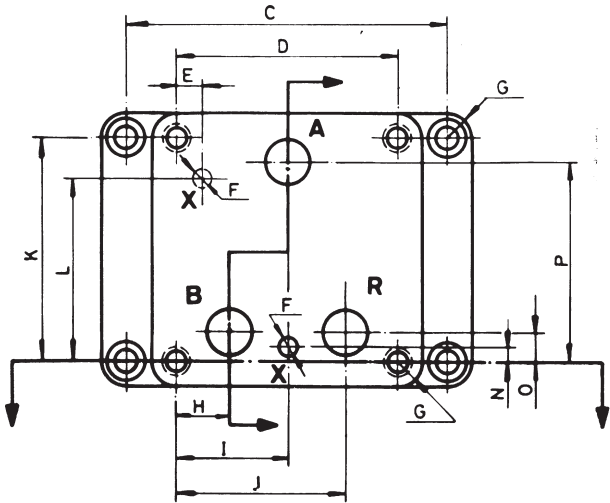

Referencia Reference	272001	272002	274001	274002
C	114,5		146	
D	76		101,5	
E	12		-	
F	7		7	
G	9,5		11	
H	19		23,8	
I	38		50,75	
J	57		77,8	
K	82,5		101,5	
L	70,5		-	
M	14		20	
N	-		6,4	
O	8		12,7	
P	73		89	
Q	13	15	15,5	16,5
S	20		20	
T	11		10	
U	M. 8		M. 10	
V	20		25	
W	15		20	
Y	9,5		11	
Z	14,5		17,5	
a	76		100	
b	61		73	
c	38		46	
d	-		25	
e	26		-	
f	67,5		-	
g	-		55	
h	15		17	
i	67,5		85	
j	1/4" BSP		1/4" BSP	
k	25		35	
l	3/8" BSP	1/2" BSP	3/4" BSP	1" BSP
Peso en kg. Weight in kg.	2,100		4,500	

REGULADOR DE CAUDAL 2 vías - 2 way COMPENSATED FLOW CONTROL VALVE

Datos técnicos hidráulicos <i>Hydraulic technical data</i>	TN-6	TN-10
Presión máxima de trabajo <i>Max working pressure</i>	250 bar	
Caudal nominal <i>Nominal flow rate</i>	35 L/min.	70 L/min.
Presión diferencial min. de regulación <i>Min. adjustment differential pressure</i>	8 bar	
Caudal mínimo regulable <i>Min. adjustable flow rate</i>	0.1 L/min.	1 L/min.
Fluido recomendado <i>Fluid to be used</i>	ISO 6743 Tipo HM, HV ó HG ISO 3448 Cat. VG32, VG46	
Gama de temperaturas del fluido <i>Fluid temperature range</i>	-20°C... +80°C	
Gama de viscosidades <i>Manual viscosity range</i>	4—500 cSt.	
Grado de limpieza del aceite <i>Recommended fluid cleanliness</i>	16/13 s/. ISO 4406 - RP70H	



Serie **1VCR**
Type

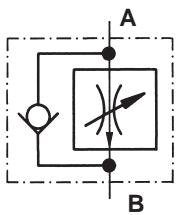

- A Entrada del aceite
Oil inlet
- B Salida regulada del aceite
Controlled oil outlet

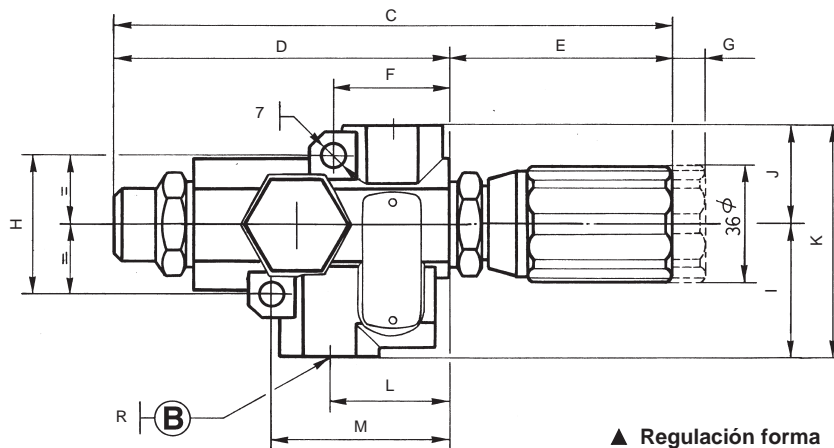

▲ Regulación forma **3**
Adjusting type

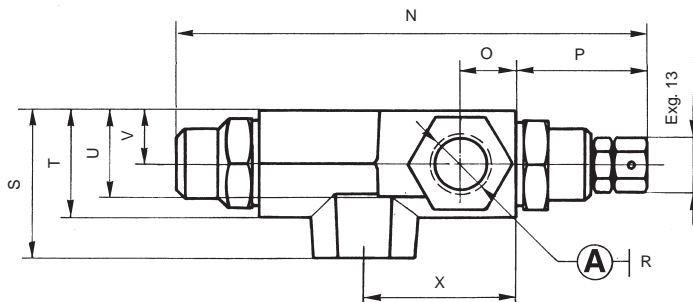

▲ Regulación forma **2**
Adjusting type

Referencia	C	D	E	F	G	H	I	J	K	L	M	N	O	P	R BSP	S	T	U	V	X	Peso kg <i>Weight kg</i>
1VCR02RsD	171	97	69	35	7,5	42	40	30	70	36	54	139	17	37	3/8"	44	32	26	16	46	0,9
1VCR03RsD	186	117		42	8	53	45	35	80	51	70	154	20		1/2"	51	23	68		1,3	

REGULADOR DE CAUDAL 2 vías - 2 way COMPENSATED FLOW CONTROL VALVE

Datos técnicos hidráulicos <i>Hydraulic technical data</i>	TN-6	TN-10
Presión máxima de trabajo <i>Max working pressure</i>	250 bar	
Caudal nominal <i>Nominal flow rate</i>	35 L/min.	70 L/min.
Presión diferencial min. de regulación <i>Min. adjustment differential pressure</i>	8 bar	
Caudal mínimo regulable <i>Min. adjustable flow rate</i>	0.1 L/min.	1 L/min.
Fluido recomendado <i>Fluid to be used</i>	ISO 6743 Tipo HM, HV ó HG ISO 3448 Cat. VG32, VG46	
Gama de temperaturas del fluido <i>Fluid temperature range</i>	-20°C... +80°C	
Gama de viscosidades <i>Manual viscosity range</i>	4—500 cSt.	
Grado de limpieza del aceite <i>Recommended fluid cleanliness</i>	16/13 s/. ISO 4406 - RP70H	

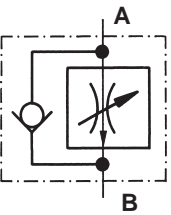

A Entrada del aceite
Oil inlet
B Salida regulada del aceite
Controlled oil outlet

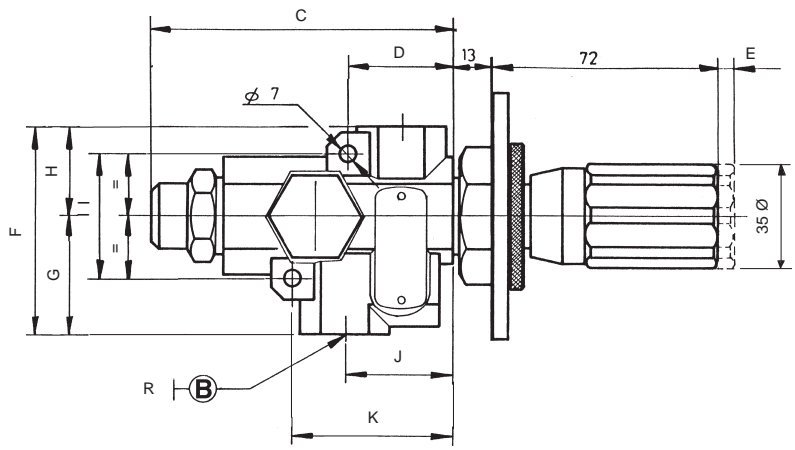
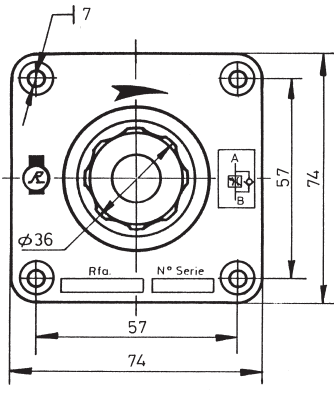

▲ Regulación forma
Adjusting type 3

▲ Regulación forma
Adjusting type 4

▲ Regulación forma
Adjusting type 1

▲ Regulación forma
Adjusting type 2

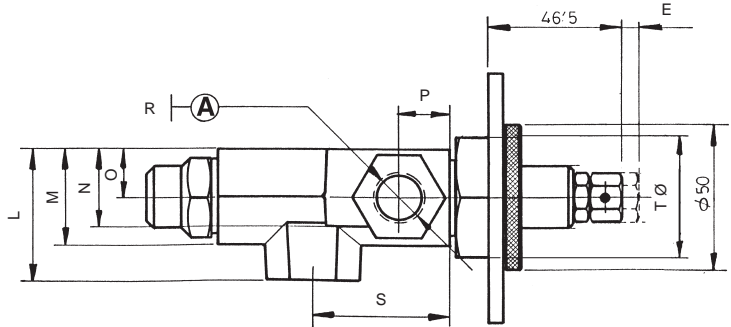
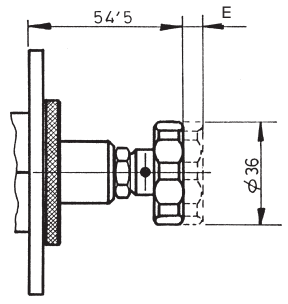
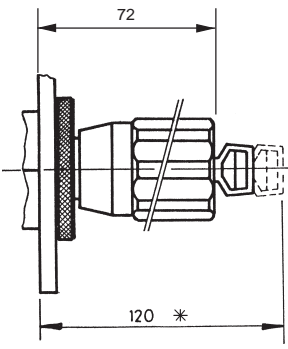

* Cota necesaria para la extracción de la llave
Min. dimension to remove key

Referencia	C	D	E	F	G	H	I	J	K	L	M	N	O	P	R BSP	S	T	Peso kg <i>Weight kg</i>
1VCRE02RsD	97	35	7,5	70	40	30	42	36	54	44		26		17	3/8"	46	41	1,3
1VCRE03RsD	117	42	8	80	45	35	53	45	70	49	32	23	16	20	1/2"	68		1,7

REGULADOR DE CAUDAL 2 vías - 2 ways COMPENSATED FLOW CONTROL VALVE

TN-6 / NG-6

Diagrama: Presión - caudal
Diagram: Pressure - flow rate

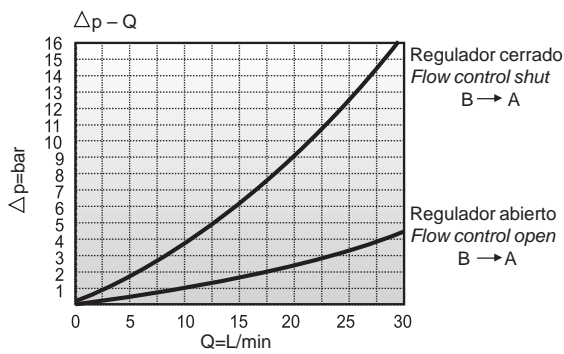
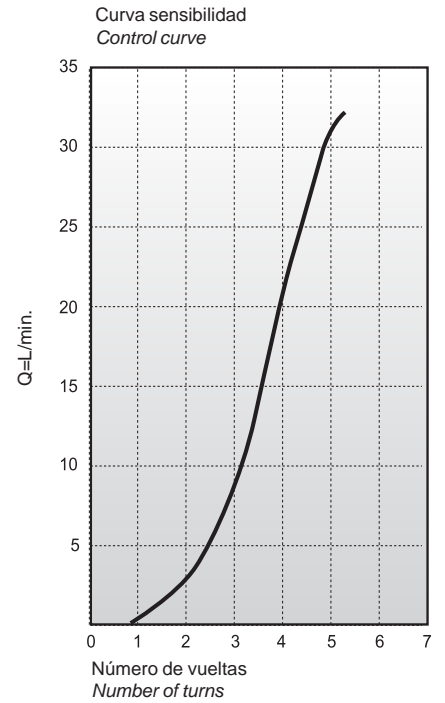
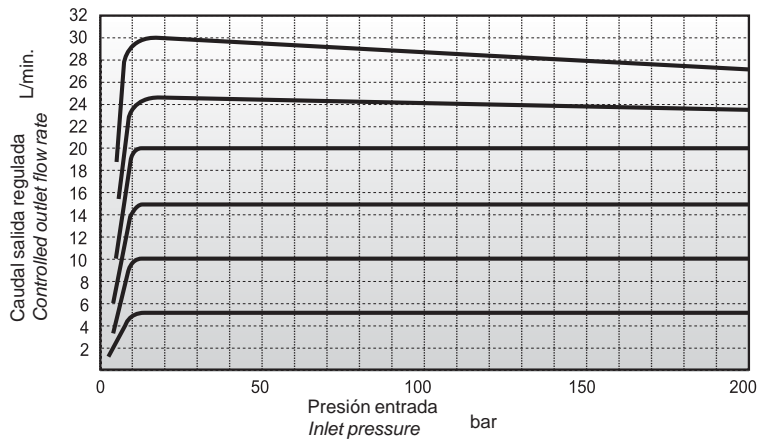

REGULADOR DE CAUDAL 2 vías - 2 ways COMPENSATED FLOW CONTROL VALVE

TN-10 / NG-10

Diagrama: Presión - caudal
Diagram: Pressure - flow rate

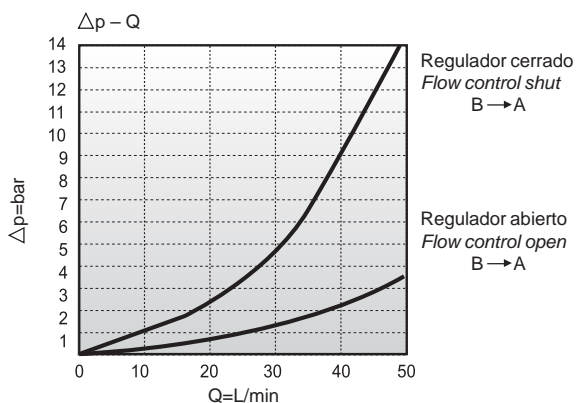
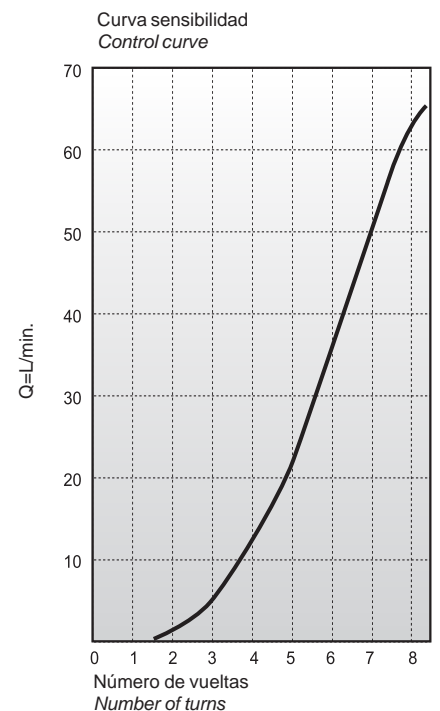
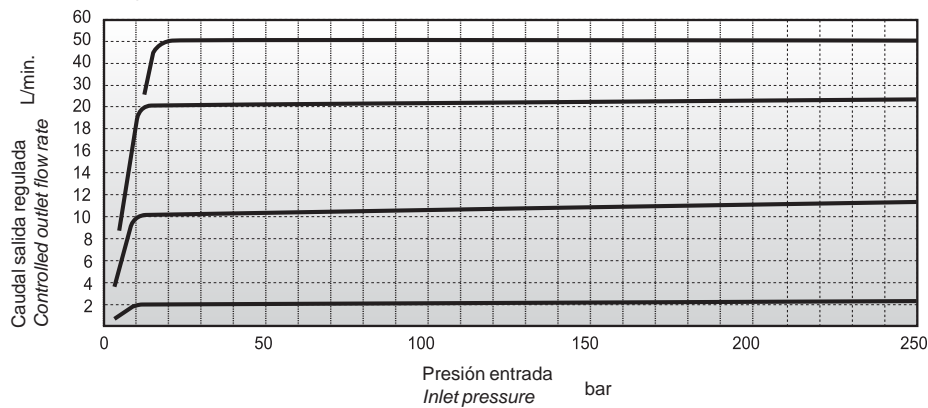

REGULADOR DE CAUDAL 3 vías - 3 way COMPENSATED FLOW CONTROL VALVE

Datos técnicos hidráulicos <i>Hydraulic technical data</i>	TN-6	TN-10
Presión máxima de trabajo <i>Max working pressure</i>	250 bar	
Caudal nominal <i>Nominal flow rate</i>	35 L/min.	70 L/min.
Presión diferencial min. de regulación <i>Min. adjustment differential pressure</i>	8 bar	
Pérdida de carga de A'R con regulador cerrado y 20 L. entrada <i>Pressure drop A'R with closed adjustment and 20 Lts. inlet flow</i>	8 bar	—
Pérdida de carga de A'R con regulador cerrado y 20 L. entrada <i>Pressure drop A'R with closed adjustment and 20 Lts. inlet flow</i>	—	8 bar
Caudal mínimo regulable <i>Min. adjustable flow rate</i>	0.1 L/min.	1 L/min.
Fluido recomendado <i>Fluid to be used</i>	ISO 6743 Tipo HM, HV ó HG ISO 3448 Cat. VG32, VG46	
Gama de temperaturas del fluido <i>Fluid temperature range</i>	-20°C... +80°C	
Gama de viscosidades <i>Manual viscosity range</i>	4—500 cSt.	
Grado de limpieza del aceite <i>Recommended fluid cleanliness</i>	16/13 s/. ISO 4406 - RP70H	



Serie
Type **1VCR**



- A Entrada del aceite
Oil inlet
- B Salida regulada del aceite
Controlled oil outlet
- R Aceite sobrante
Exceeding flow rate

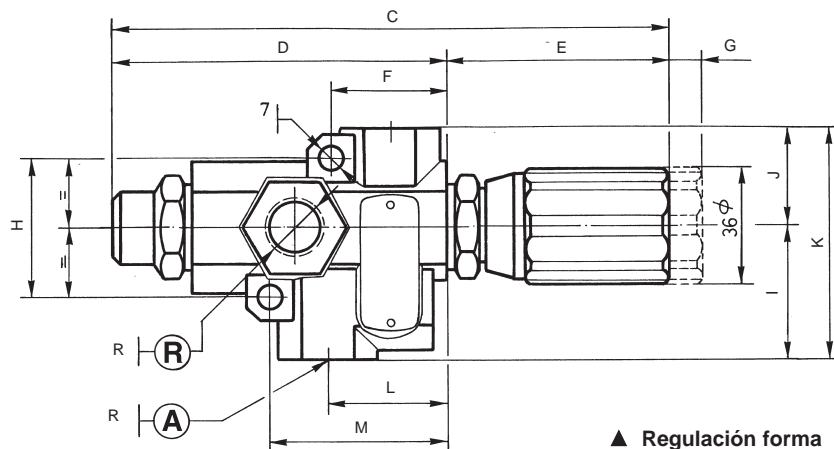

▲ Regulación forma 3
Adjusting type

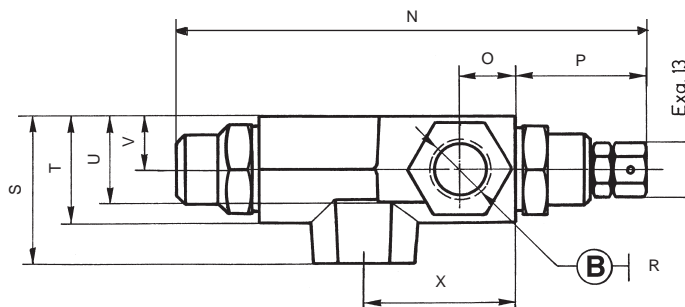

▲ Regulación forma 2
Adjusting type

Referencia	C	D	E	F	G	H	I	J	K	L	M	N	O	P	R BSP	S	T	U	V	X	Peso kg Weight kg
1VCR02RsT	171	102	69	35	7,5	42	40	30	70	36	54	139	17	37	3/8"	44	32	26	16	46	0,9
1VCR03RsT	198	129		42	8	53	45	35	80	41	70	166	20		1/2"	49		23		68	1,3

REGULADOR DE CAUDAL 3 vías - 3 way COMPENSATED FLOW CONTROL VALVE

Datos técnicos hidráulicos <i>Hydraulic technical data</i>	TN-6	TN-10
Presión máxima de trabajo <i>Max working pressure</i>	250 bar	
Caudal nominal <i>Nominal flow rate</i>	35 L/min.	70 L/min.
Presión diferencial min. de regulación <i>Min. adjustment differential pressure</i>	8 bar	
Pérdida de carga de A/R con regulador cerrado y 20 L. entrada <i>Pressure drop A/R with closed adjustment and 20 Lts. inlet flow</i>	8 bar	—
Pérdida de carga de A/R con regulador cerrado y 20 L. entrada <i>Pressure drop A/R with closed adjustment and 20 Lts. inlet flow</i>	—	8 bar
Caudal mínimo regulable <i>Min. adjustable flow rate</i>	0.1 L/min.	1 L/min.
Fluido recomendado <i>Fluid to be used</i>	ISO 6743 Tipo HM, HV ó HG ISO 3448 Cat. VG32, VG46	
Gama de temperaturas del fluido <i>Fluid temperature range</i>	-20°C... +80°C	
Gama de viscosidades <i>Manual viscosity range</i>	4—500 cSt.	
Grado de limpieza del aceite <i>Recommended fluid cleanliness</i>	16/13 s/. ISO 4406 - RP70H	



Serie
Type **1VCRE**

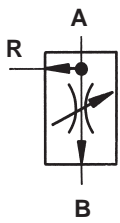

- A Entrada del aceite
Oil inlet
- B Salida regulada del aceite
Controlled oil outlet
- R Aceite sobrante
Exceeding flow rate

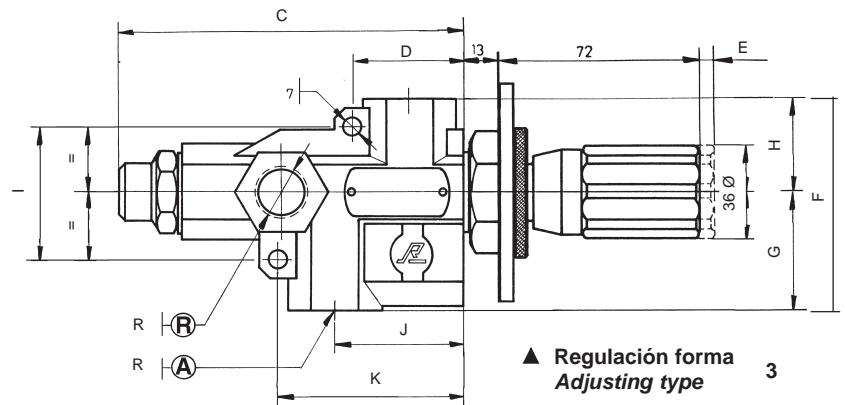
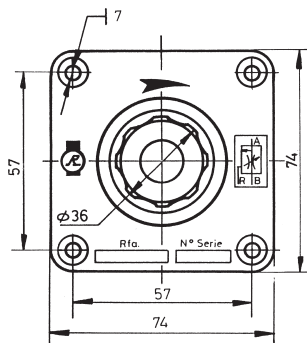

▲ Regulación forma
Adjusting type **3**

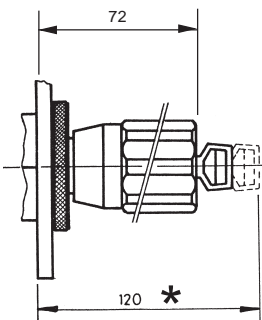

▲ Regulación forma
Adjusting type **4**

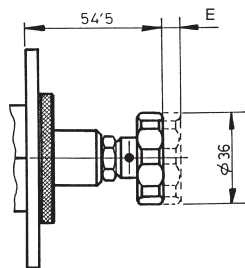

▲ Regulación forma
Adjusting type **1**

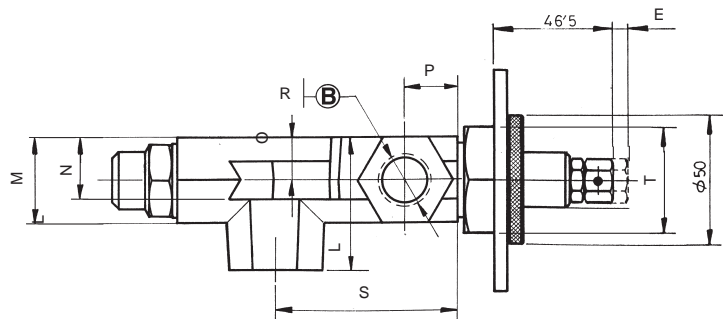

▲ Regulación forma
Adjusting type **2**

* Cota necesaria para la extracción de la llave
Min. dimension to remove key

Referencia	C	D	E	F	G	H	I	J	K	L	M	N	O	P	R BSP	S	T	Peso kg <i>Weight kg</i>
1VCRE02RsT	102	35	7,5	70	40	30	42	36	54	44	32	26	16	17	3/8"	46	41	1,3
1VCRE03RsT	129	42	8	80	45	35	53	45	70	49	31	30	16	20	1/2"	68	41	1,7

Ejemplo para pedido de recambios
Example to order spare parts

Cantidad Quantity	Denominación Description	Nº de la pieza Part number	Referencia según la placa Rfa. according serial number plate
1	Tornillo regulación Adjusting screw	5	Para válvula For valve 1VCRE02R3T

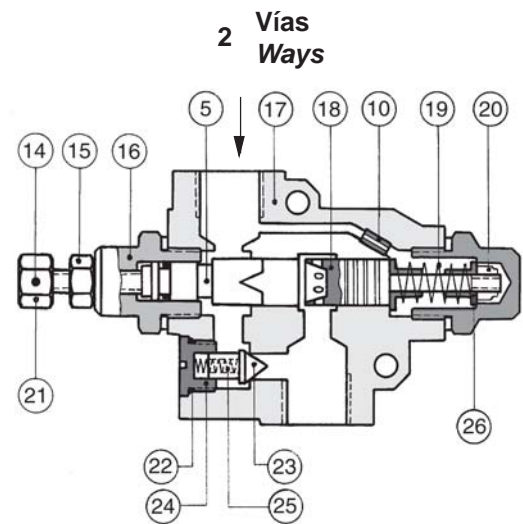
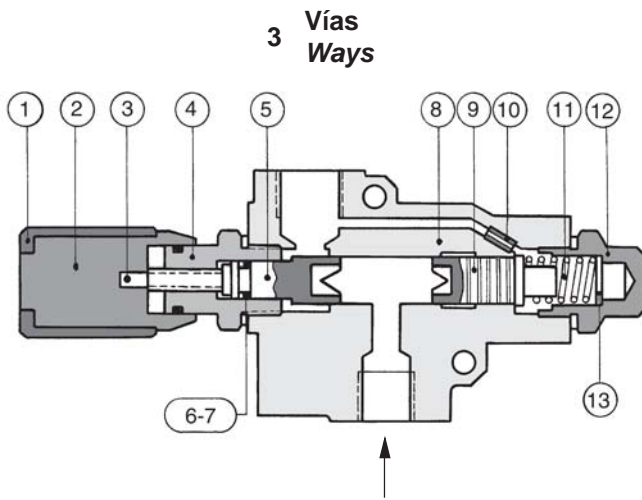

Variantes / Alternatives

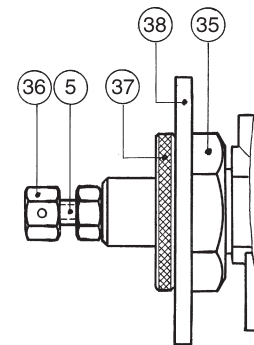
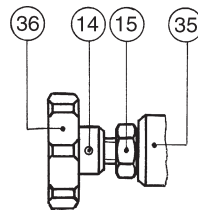
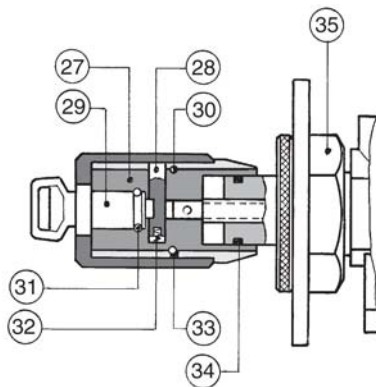

NUM.	Denominación Description	Cant. Quant.	NUM.	Denominación Description	Cant. Quant.	NUM.	Denominación Description	Cant. Quant.
1	Suplemento volante Knop cover	1	14	Pasador elástico Elastic pin	1	27	Guía volante Knob guide	1
2	Volante regulación Knop	1	15	Tuerca Nut	1	28	Pieza fijación Knob fixing pin	1
3	Pasador elástico Elastic pin	1	16	Adaptador Adaptor	1	29	Cerradura Locking system	1
4	Adaptador volante Knop adaptor	1	17	Cuerpo válvula Valve housing	1	30	Bolas Balls	30
5	Tornillo regulación Adjusting screw	1	18	Corredera compensadora Spool	1	31	Pasador Elastic pin Ø 2 x 20	1
6	Junta tórica O Ring Ø 8,9 x 1,9	1	19	Muelle Spring	1	32	Muelle Spring	1
7	Junta antiextrusión Antiextrusion gasket	1	20	Tuerca Nut	1	33	Tapón tope bolas Plug	1
8	Cuerpo válvula Valve housing	1	21	Tuerca Nut	1	34	Junta tórica O Ring Ø 16,9 x 2,7	1
9	Corredera compensadora Spool	1	22	Junta tórica O Ring Ø 12,4 x 1,8	1	35	Adaptador Adaptor	1
10	Tornillo reg. paso aceite Oil throttling screw	1	23	Válvula retención Chek valve	1	36	Volante regulación Knob	1
11	Muelle Spring	1	24	Tapón válvula Plug	1	37	Arandela fijación placa Washer	1
12	Tapón final Plug	1	25	Muelle Spring	1	38	Placa fijación Fixing flange	1
13	Arandela tope muelle Washer	1	26	Guía muelle Spring guide	2			

REGULADOR DE CAUDAL 3 vías - 3 ways COMPENSATED FLOW CONTROL VALVE

TN-6 / NG-6

Diagrama: Presión - caudal
Diagram: Pressure - flow rate

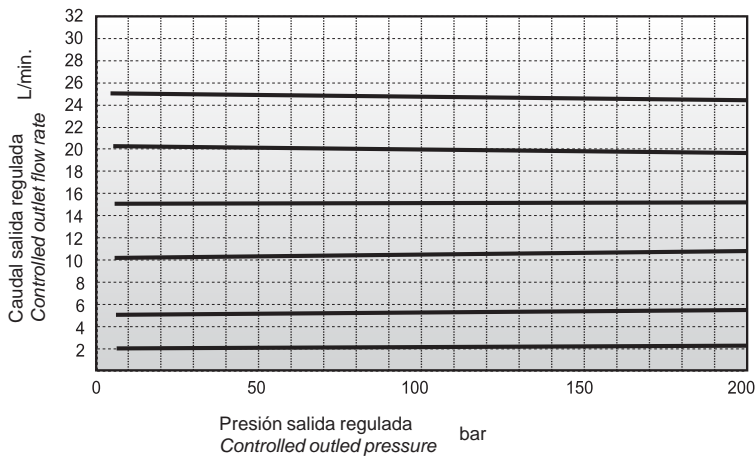

Curva sensibilidad
Control curve

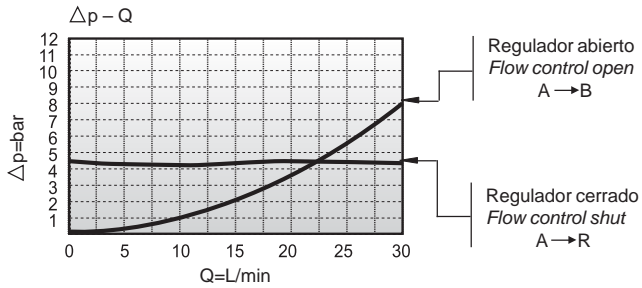
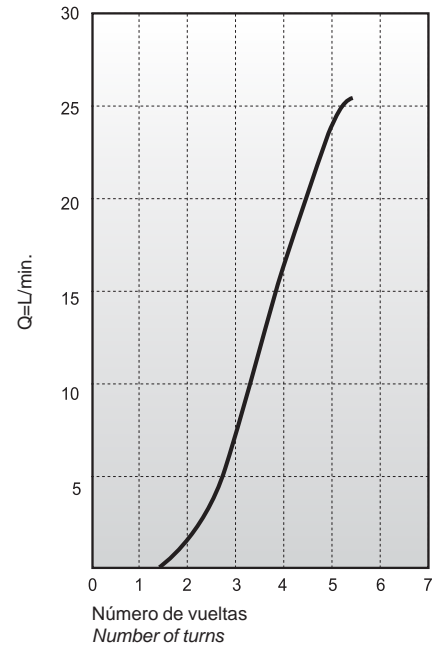

REGULADOR DE CAUDAL 3 vías - 3 ways COMPENSATED FLOW CONTROL VALVE

TN-10 / NG-10

Diagrama: Presión - caudal
Diagram: Pressure - flow rate

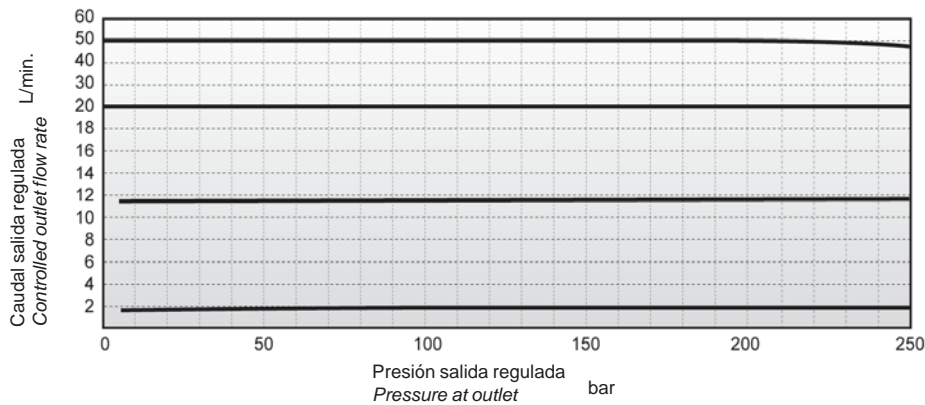

Curva sensibilidad
Control curve

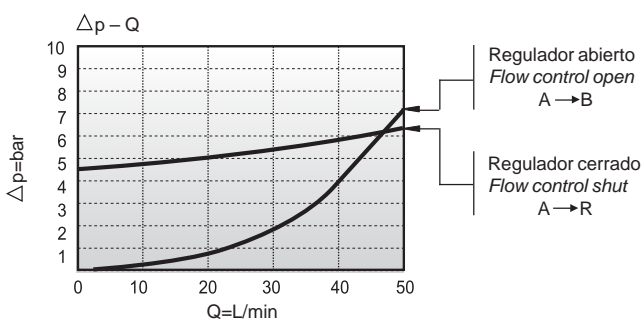
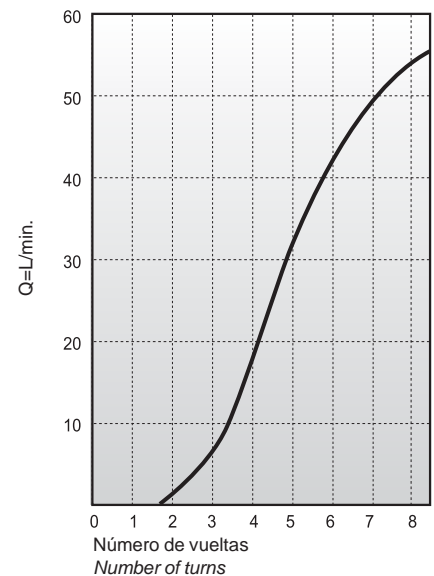

REPARTIDOR DE CAUDAL - *FLOW DIVIDER*

TN-10

Datos técnicos hidráulicos
Hydraulic technical data

Presión máxima de trabajo <i>Max working pressure</i>	250 bar
Caudal nominal <i>Nominal flow rate</i>	60 L/min.
Fluido recomendado <i>Fluid to be used</i>	ISO 6743 Tipo HM, HV ó HG ISO 3448 Cat. VG32, VG46
Gama de temperaturas del fluido <i>Fluid temperature range</i>	-20°C... +80°C
Gama de viscosidades <i>Manual viscosity range</i>	4—500 cSt.
Grado de limpieza del aceite <i>Recommended fluid cleanliness</i>	16/13 s/. ISO 4406 - RP70H
Peso <i>Weight</i>	1,2 Kg.



RFA: RC04R*

Caudal prioritario en P L/min. <i>Flow priority and P L/min</i>
4,5 - 6,6 - 10,6 - 13,5 - 21,5 - 23,5 - 27,5

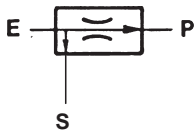

E = Caudal entrada / *Inlet flow*
S = Caudal sobrante / *Secondary flow*
P = Caudal prioritario / *Priority flow*



DIAGRAMA:
DIAGRAM: Δ — Q a 23 cSt.



Toma:
Port: P

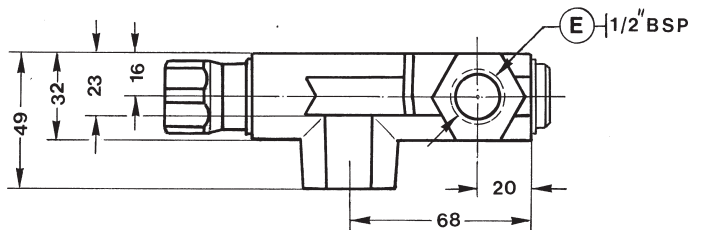
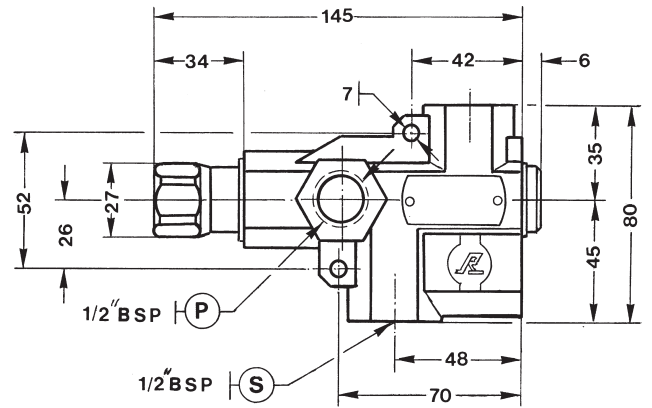
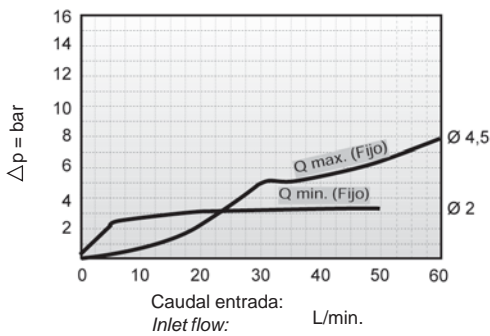
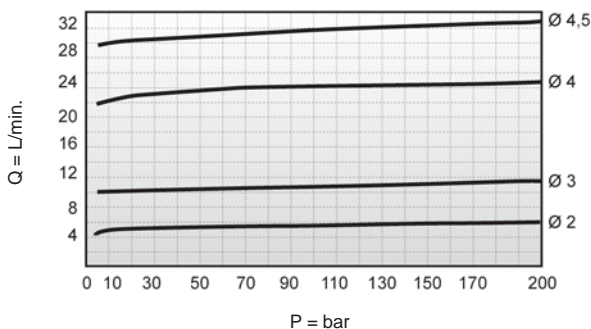

Toma:
Port: S

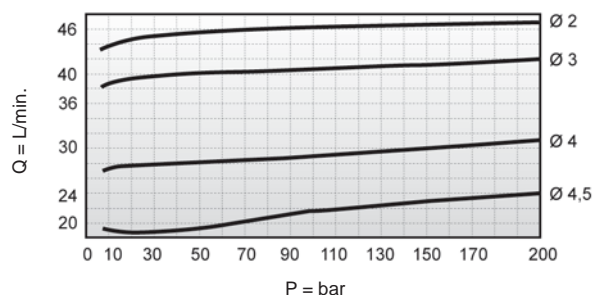

Ejemplo para pedido de recambios
Example to order spare parts

Cantidad Quantity	Denominación Description	Nº de la pieza Part number	Referencia según la placa Rfa. according serial number plate
1	Muelle Spring	2	RC04R10,6

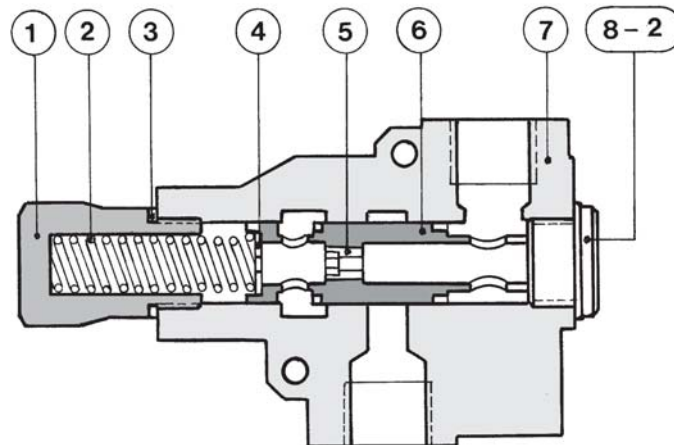

Núm.	Denominación Description	Cant. Quant.
1	Tapón válvula seguridad Safety valve cover	1
2	Muelle Spring	1
3	Junta metal buna Metal bonded gasket	1
4	Arandela Washer	1
5	Tornillo regulador paso aceite Oil throttling screw	1
6	Válvula Poppet	1
7	Cuerpo válvula Valve housing	1
8	Tapón Plug	1

DIVISOR DE CAUDAL - FLOW DIVIDER

Datos técnicos hidráulicos Hydraulic technical data

Presión máxima de trabajo <i>Max working pressure</i>	250 bar
Caudal nominal <i>Nominal flow rate</i>	Ver gráficos <i>See curves</i>
Fluido recomendado <i>Fluid to be used</i>	ISO 6743 Tipo HM, HV ó HG ISO 3448 Cat. VG32, VG46
Gama de temperaturas del fluido <i>Fluid temperature range</i>	-20°C... +80°C
Gama de viscosidades <i>Manual viscosity range</i>	4—500 cSt.
Grado de limpieza del aceite <i>Recommended fluid cleanliness</i>	16/13 s/. ISO 4406 - RP70H
Peso <i>Weight</i>	1,250 Kg.



Referencia	Caudal entrada <i>Inlet flow</i> L/min.
DC03R5	1,5 – 5
DC03R10	4 – 10
DC03R15	5 – 15
DC03R25	10 – 25
DC03R30	20 – 30
DC03R40	25 – 40
DC03R50	30 – 50

En la elección de un caudal determinado es preferible siempre utilizar el valor del campo de regulación inferior. EJEMPLO: caudal entrada 8 L/min. utilizar DC03R10.

For highest accuracy always use the smallest possible flow range.

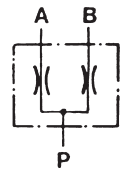

El caudal dividido puede tener una variación entre tomas de $\pm 3\%$.
Split flow may have a variation between ports of $\pm 3\%$.

DIAGRAMA: $\Delta p - Q$
DIAGRAM:

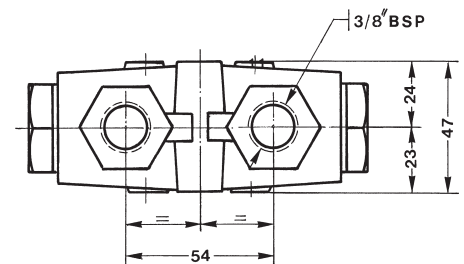
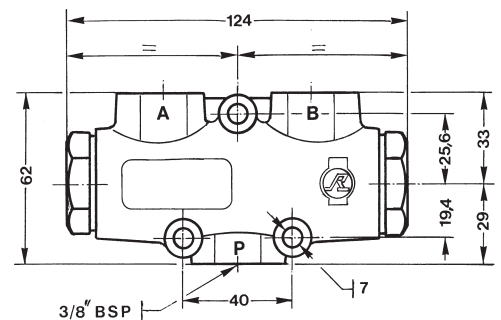
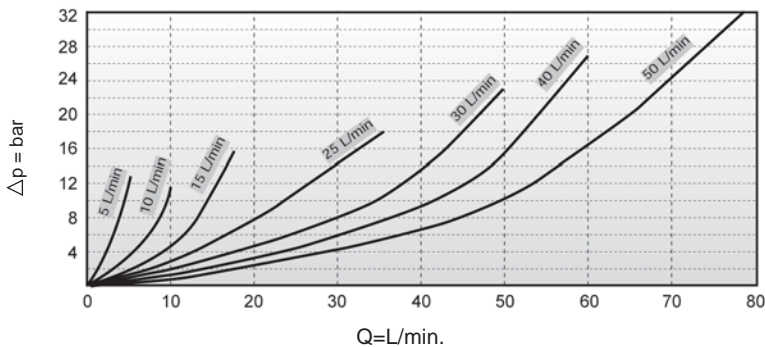

La marca nº 5 solo se montará para caudales de 1,5 a 10 L/min.
Part number 5 is only fitter to DC03R5 and DC03R10.

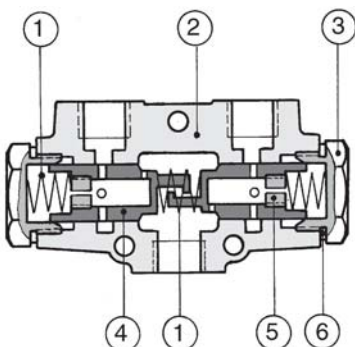

Núm.	Denominación <i>Description</i>	Cant. <i>Quant.</i>
1	Muelle <i>Spring</i>	3
2	Cuerpo vcalvula <i>Valve body</i>	1
3	Tapón <i>Plug</i>	2
4	Corredera <i>Spool</i>	2
5	Tornillo reg. paso aceite <i>Orifice plug</i>	2
6	Junta metal buna <i>Bonded seal</i>	2

Bloque modular selector de caudal TOMA "A"
Modular flow selector PORT "A"

NOMENCLATURA DE REFERENCIAS	M8082	-	3	-	1	R	220-50	CODING SYSTEM
------------------------------------	--------------	----------	----------	----------	----------	----------	---------------	----------------------

Funciones Function	
M8082	Bloque modular selector de caudal Modular flow selector

Tensión y frecuencias Voltaje	
DC	12V - 24V - 48V
AC	24V - 48V - 110V - 220V (50 Hz) 115V - 230V (60Hz)

Forma de regulación Control type	
2	Regulación por tuercas Locknut
3	Regulación por volante Konb
4	Regulación por volante con llave Konb with key

Tipo de corriente Voltaje type	
C	Continua / DC
R	Alterna / AC

Selector de caudal según variante Version	
1 - 2 - 3 - 4	

Montando las placas 321006 y 321007 se invierte el sentido de regulación.

Using adaptor plates 321006 - 321007 the control direction is reverted.

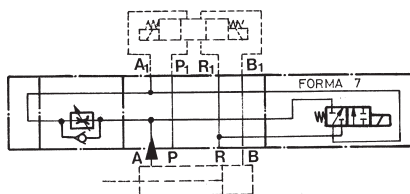
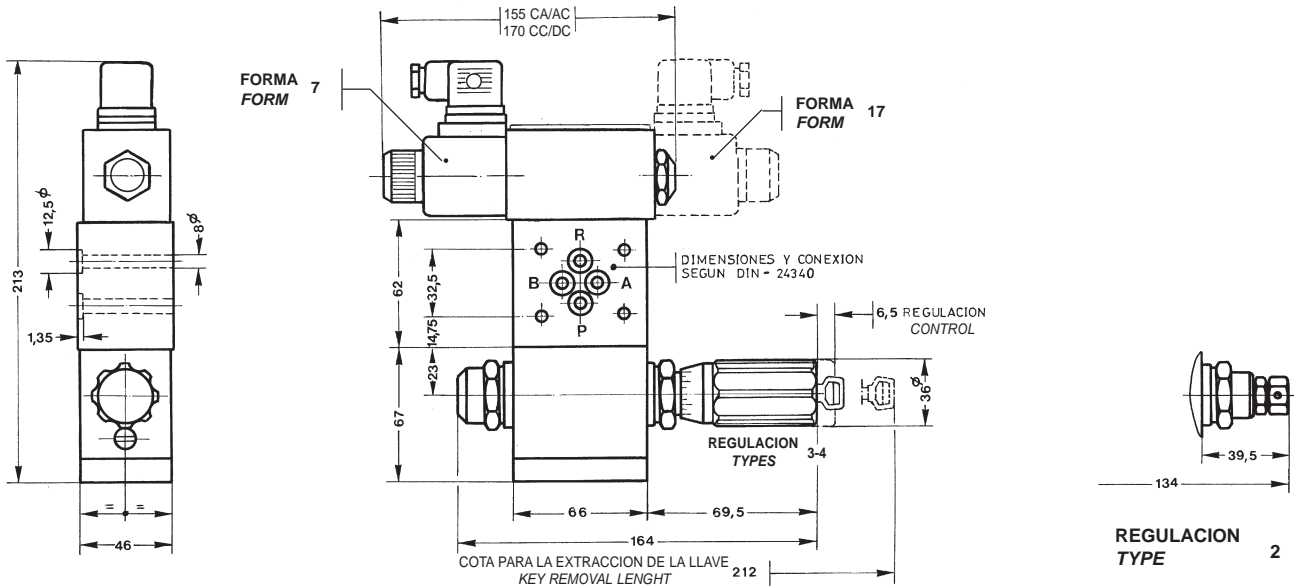

VARIANTE 1: Regulación por "A" en la entrada. Velocidad lenta.
 VERSION 1: Slow meter out.

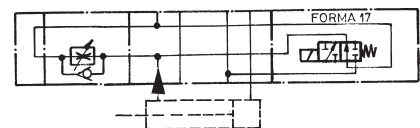

VARIANTE 2: Regulación por "A" en la entrada. Velocidad rápida.
 VERSION 2: Fast meter out.

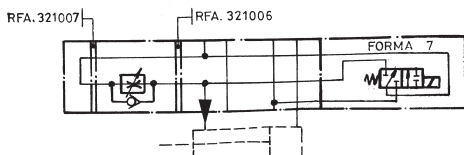

VARIANTE 3: Regulación por "A" en la salida. Velocidad lenta.
 VERSION 3: Slow meter in.

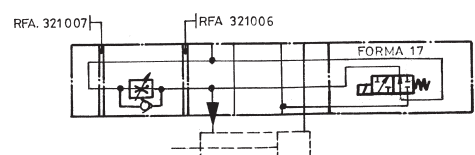

VARIANTE 4: Regulación por "A" en la salida. Velocidad rápida.
 VERSION 4: Fast meter in.

VALVULA DE FRENADO - BRAKING VALVE

**Datos técnicos hidráulicos
Hydraulic technical data**

Presión máxima de trabajo Max working pressure	250 bar
Caudal nominal Nominal flow rate	Ver gráficos See curves
Fluido recomendado Fluid to be used	ISO 6743 Tipo HM, HV ó HG ISO 3448 Cat. VG32, VG46
Gama de temperaturas del fluido Fluid temperature range	-20°C... +80°C
Gama de viscosidades Manual viscosity range	4—500 cSt.
Grado de limpieza del aceite Recommended fluid cleanliness	16/13 s/. ISO 4406 - RP70H
Peso Weight	0,2 kg.



RFA: VF03R*

Caudal nominal Nominal flow rate	± 10% a 100 bar
10 - 14 - 21 - 25 - 29 - 34 - 37 - 45 - 55	

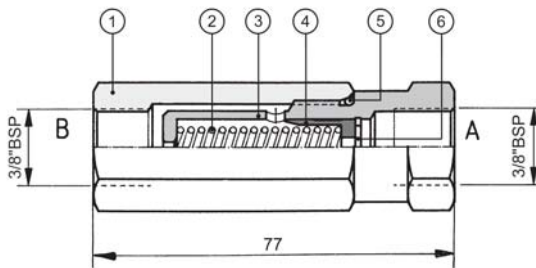
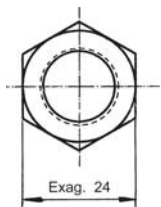

Núm.	Denominación Description	Cant. Quant.
1	Cuerpo válvula Valve body	3
2	Muelle Spring	1
3	Tapón guía émbolo Plug	2
4	Embolo Restrictor piston	2
5	Junta tórica O ring $\varnothing 17 \times 2$	2
6	Anillo elástico Circlip	2

DIAGRAMA: Presión-caudal
DIAGRAM: Pressure-flow rate B → A



DIAGRAMA: Presión-caudal
DIAGRAM: Pressure-flow rate A → B



VALVULA DE FRENADO - BRAKING VALVE

Datos técnicos hidráulicos <i>Hydraulic technical data</i>	
Presión máxima de trabajo <i>Max working pressure</i>	210 bar
Caudal nominal <i>Nominal flow rate</i>	1 - 9 L./min
Fluido recomendado <i>Fluid to be used</i>	ISO 6743 Tipo HM, HV ó HG ISO 3448 Cat. VG32, VG46
Gama de temperaturas del fluido <i>Fluid temperature range</i>	-20°C... +80°C
Gama de viscosidades <i>Manual viscosity range</i>	ISO 3448 CAT. VG32-VG46
Grado de limpieza del aceite <i>Recommended fluid cleanliness</i>	16/13 s./ ISO 4406 o RP70H

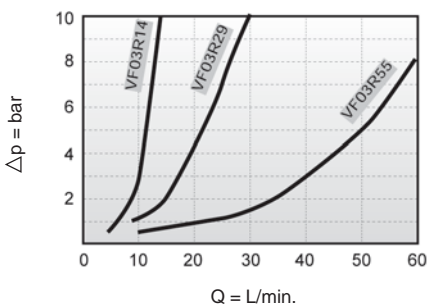
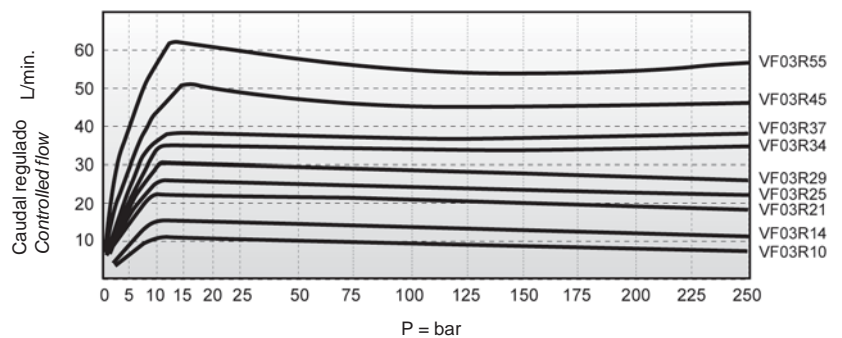

RFA: VF02R*

Caudal nominal <i>Nominal flow rate</i>	± 10% a 100 bar
1 - 2 - 3 - 4 - 5 - 6 - 7 - 8 - 9	

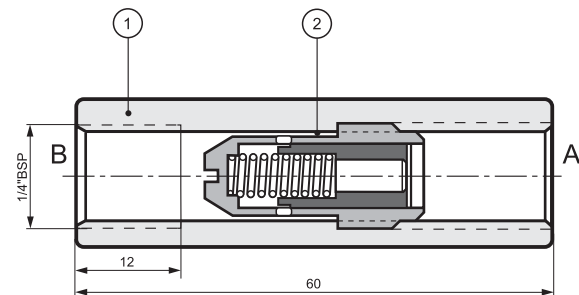
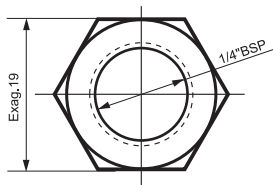
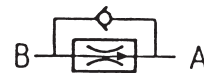

Núm.	Denominación <i>Description</i>	Cant. <i>Quant.</i>
1	Cuerpo válvula <i>Valve body</i>	1
2	Regulador caudal <i>Flow control valve</i>	1

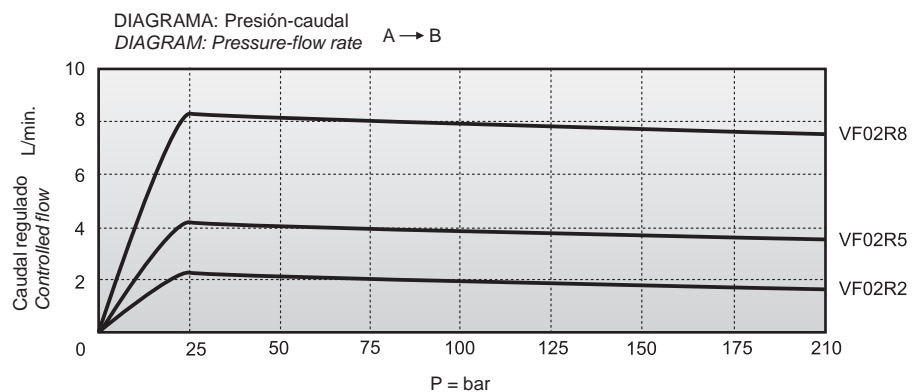
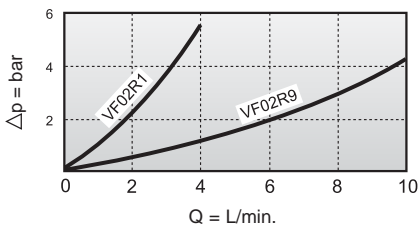

Datos técnicos hidráulicos Hydraulic technical data	
Presión máxima de trabajo Max. working pressure	350 bar
Caudal nominal Nominal flow rate	Ver gráficos See curves
Fluido recomendado Fluid to be used	ISO 6743 Tipo HM, HV ó HG ISO 3448 Cat. VG32, VG46
Gama de temperaturas del fluido Fluid temperature range	-20°C... +80°C
Gama de viscosidades Manual viscosity range	4—500 cSt.
Grado de limpieza del aceite Recommended fluid cleanliness	16/13 s./ ISO 4406 o RP70H

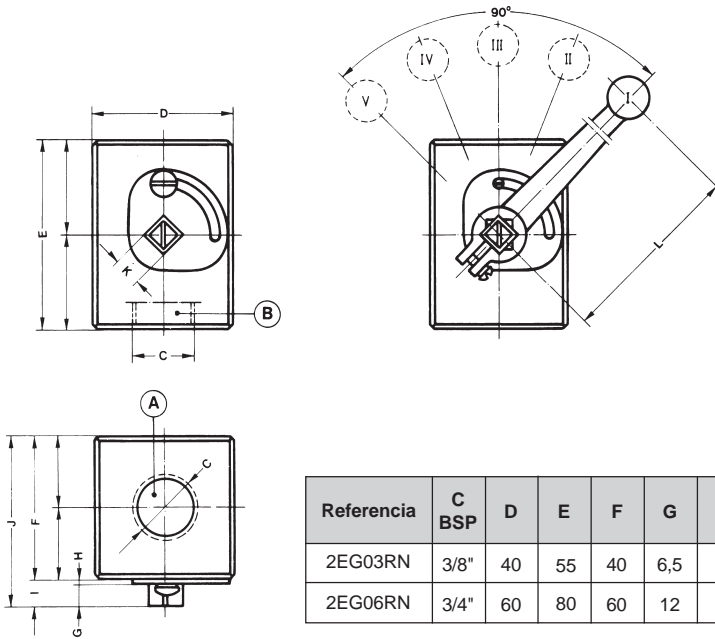

Referencia	C BSP	D	E	F	G	H	I	J	K	L	Peso kg. Weight kg.
2EG03RN	3/8"	40	55	40	6,5	2	8,5	48,5	8	100	0,650
2EG06RN	3/4"	60	80	60	12	2	14	74	14	130	2



DIAGRAMAS:
DIAGRAMS: $\Delta p - Q$

TIPO:
TYPE: 3/8"

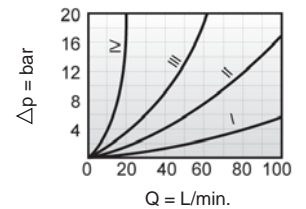

TIPO:
TYPE: 3/4"

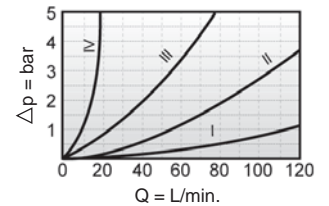

Ejemplo para pedido de recambios Example to order spare parts

Cantidad Quantity	Denominación Description	Nº de la pieza Part number	Referencia según la placa Rfa. according serial number plate
1	Tornillo tope Screw	5	Para válvula For valve 2EG03RN

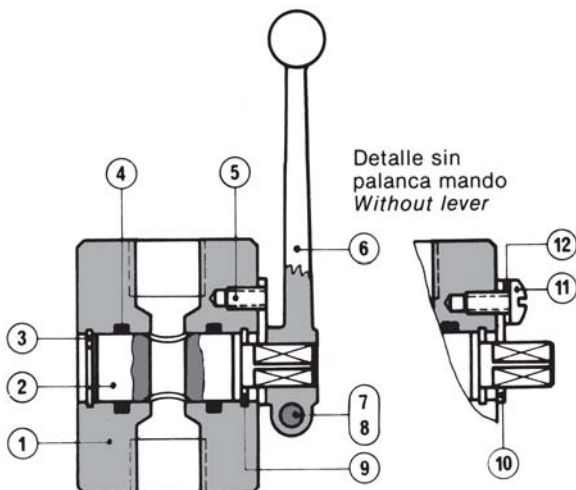

Núm.	Denominación Description	Cant. Quant.	Núm.	Denominación Description	Cant. Quant.
1	Cuerpo estrangulador Valve housing	1	7	Arandela Washer DIN-7980Ø5	1
2	Estrangulador paso aceite Throttle cam	1	8	Tornillo Screw DIN-85 M5x15	1
3	Anillo elástico Elastic ring	1	9	Anillo elástico Elastic ring	1
4	Juntas tóricas O ring	2	10	Pieza fijación Fixing part	1
5	Tornillo tope Screw	1	11	Tornillo Screw DIN-85 M5x10	1
6	Palanca accionamiento Actuating lever	1	12	Arandela Washer DIN-125	1

ESTRANGULADOR CON VALVULA UNIDIRECCIONAL - RESTRICTOR WITH CHECK VALVE

Datos técnicos hidráulicos Hydraulic technical data	
Presión máxima de trabajo Max working pressure	250 bar
Caudal nominal Nominal flow rate	20 L/min.
Fluido recomendado Fluid to be used	ISO 6743 Tipo HM, HV ó HG ISO 3448 Cat. VG32, VG46
Gama de temperaturas del fluido Fluid temperature range	-20°C... +80°C
Gama de viscosidades Manual viscosity range	4—500 cSt.
Grado de limpieza del aceite Recommended fluid cleanliness	16/13 s./ ISO 4406 o RP70H
Peso Weight	0,100 kg.



RFA: 921600

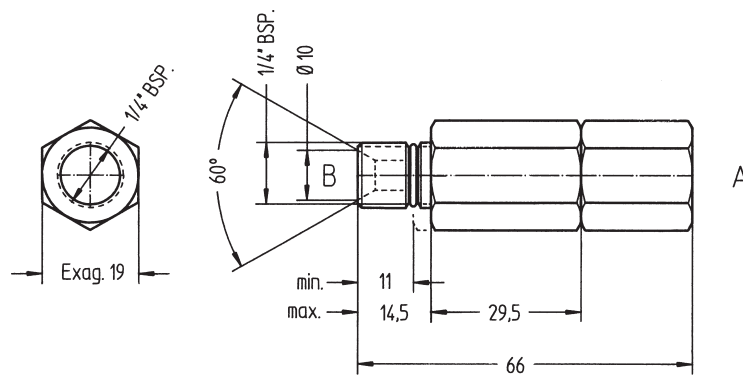

DIAGRAMAS: $\Delta p - Q$
DIAGRAMS: $\Delta p - Q$

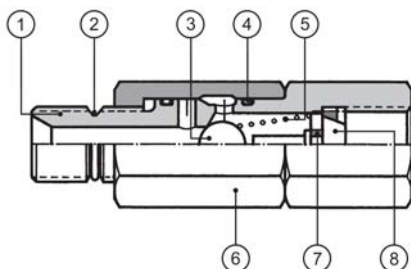
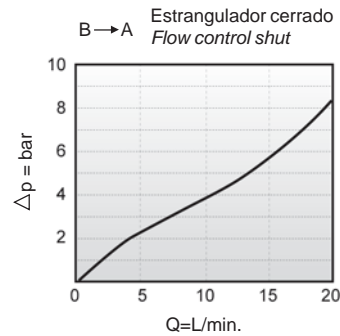
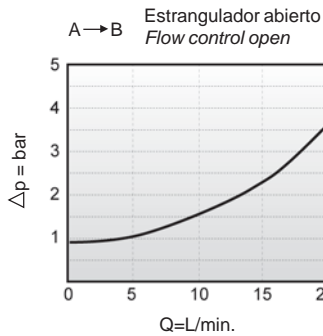

Núm.	Denominación Description	Cant. Quant.
1	Cuerpo válvula Valve housing	1
2	Anillo elástico Elastic ring	1
3	Bola Ball	1
4	Junta tórica $\varnothing 13,1 \times 1,6$ O ring	2
5	Muelle Spring	1
6	Anillo estrangulador Elastic ring	1
7	Tope muelle Valve guide	1
8	Tubo tope anillo Ring end tube	1

ESTRANGULADOR CON VALVULA UNIDIRECCIONAL - RESTRICTOR WITH CHECK VALVE

Datos técnicos hidráulicos Hydraulic technical data	
Presión máxima de trabajo Max working pressure	350 bar
Caudal nominal Nominal flow rate	Ver gráficos See curves
Fluido recomendado Fluid to be used	ISO 6743 Tipo HM, HV ó HG ISO 3448 Cat. VG32, VG46
Gama de temperaturas del fluido Fluid temperature range	-20°C... +80°C
Gama de viscosidades Manual viscosity range	4—500 cSt.
Grado de limpieza del aceite Recommended fluid cleanliness	16/13 s./ ISO 4406 o RP70H

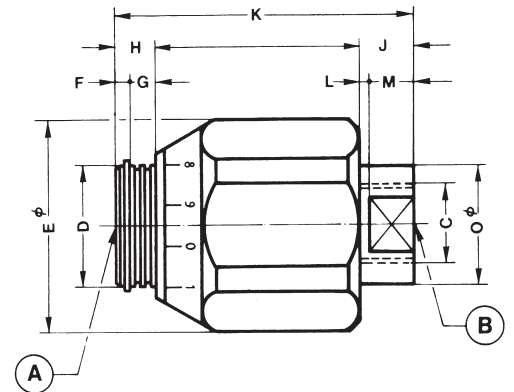
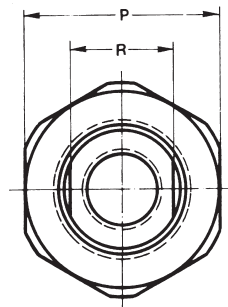
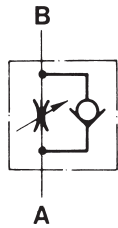

NOTA: La longitud "G" representa la carrera de regulación, habiendo que dar "N" vueltas para quedar completamente abierto.

NOTE: Length "G" means knob stroke, by turning "N" times for full opening.

Referencia	C BSP	D	E	F	G	H	I	J	K	L	M	N	O	P	R	Peso kg. Weight kg.
EG02RVR	1/4"	20	35	3	4,5	7,5	36	10	54	1,5	8,5	4,5	22	32	19	0,25
EG03RVR	3/8"	25	44	3	6	9	43	11	63	1,5	9,5	6	25	41	22	0,5
EG06RVR	3/4"	38	64	4,5	9	13,5	62,5	15	94	4	11	6	39	60	32	1,5
EG10RVR	1 1/4"	58	87	6	12	18	100	22	140	4	18	8	58	80	50	4,5

DIAGRAMAS: $\Delta p - Q$
DIAGRAMS: $\Delta p - Q$

Sentido del flujo regulado y con el estrangulador abierto.

Controlled flow sense, with knob full open.

B → A

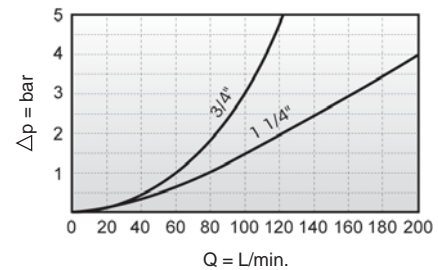
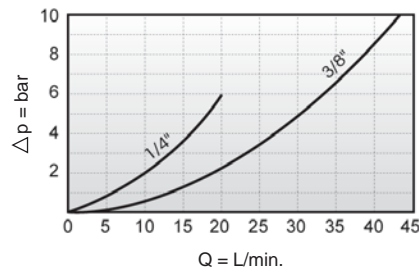

Sentido del flujo libre y con el estrangulador cerrado.

Free flow sense, with knob full closed.

A → B

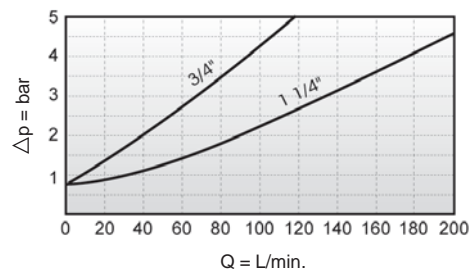
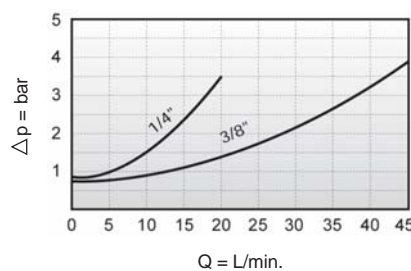

Ejemplo para pedido de recambios
Example to order spare parts

Cantidad Quantity	Denominación Description	Nº de la pieza Part number	Referencia según modelo Code system
1	Junta tórica O ring	5	Para válvula For valve EG02RVR

TIPOS
TYPES 1/4" - 3/8"

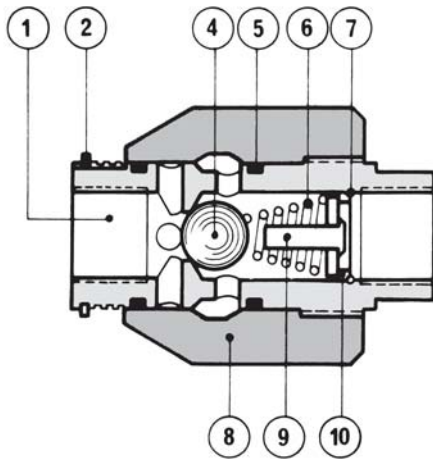

TIPOS
TYPES 3/4" - 1 1/4"

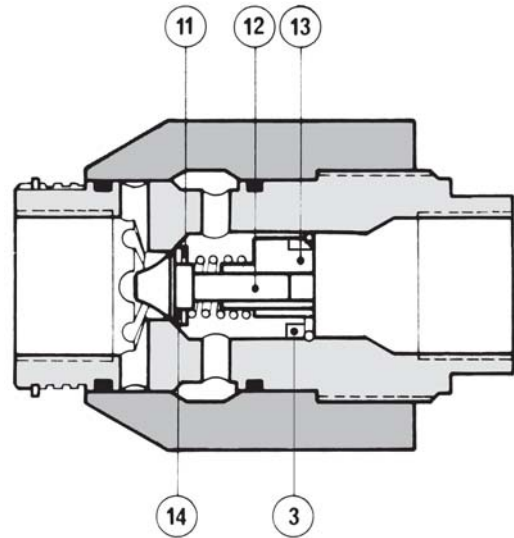

Núm.	Denominación Description	Cant. Quant.
1	Cuerpo estrangulador Valve housing	1
2	Anillo elástico Elastic ring	1
3	Anillo tope Ring end	1
4	Bola retención Ball	1
5	Juntas tóricas O ring	2
6	Muelle Spring	1
7	Anillo elástico Elastic ring	1
8	Anillo estrangulador Throttle ring	1
9	Tope muelle y bola Valve guide	1
10	Tubo tope anillo Ring end tube	1
11	Arandela Washer	1
12	Válvula Valve	1
13	Tope válvula Valve guide	1
14	Junta O ring	1